

KSTAR

INSTALLATION, OPERATION &
MAINTENANCE MANUAL

E8KD/E10KD/E12KD/E15KD
ENERGY STORAGE SYSTEM

202507|Ver:2.0

Table of Contents

1 ABOUT THIS MANUAL	3
1.1 Purpose	3
1.2 Intended Audience	3
1.3 Conventions.....	3
1.4 Change History	4
2 SAFETY INSTRUCTIONS	5
2.1 Limitation of Liability	5
2.2 Warning Signs	6
2.3 Battery Safety	7
2.3.1 General Instructions.....	8
2.3.2 Maintenance of Battery Packs	9
2.3.3 Disposal of Battery Packs.....	9
2.4 Before Installation	10
2.5 Installation Safety	12
2.6 Operation Safety.....	14
2.7 Maintenance Safety.....	16
2.8 Disposal Safety.....	17
3 PRODUCT INTRODUCTION.....	18
3.1 Features	18
3.2 Delivery Scope	18
3.3 Model.....	18
3.3.1 Inverter Model.....	19
3.3.2 Battery Pack Model.....	19
3.4 Inverter Appearance	19
3.4.1 LCD Screen	20
3.4.2 Breaker and terminal	20
3.4.3 Ports	21
3.5 Battery Pack Appearance	22
3.6 Energy Management System (EMS)	23
3.7 Parallel System.....	23
3.8 Scenarios.....	24
3.8.1 DC-coupling System	24
3.8.2 AC-coupling System	24
3.9 Wiring Diagram.....	26
3.9.1 Rapid Shutdown Device	26

3.10 System States	27
3.10.1 Inverter States	27
3.10.2 Battery Pack States	28
3.11 Working Modes.....	28
3.11.1 SELF CONSUME	28
3.11.2 BAT PRIORITY	28
3.11.3 PEAK SHIFT.....	29
4 INSTALLATION	30
4.1 Checking the Package.....	30
4.1.1 Hybrid Inverter Components.....	31
4.1.2 Battery Pack Components	31
4.1.3 Cables.....	32
4.2 Preparing Tools and Instruments.....	33
4.3 Installation Position Requirements	34
4.3.1 Restrictions	34
4.3.2 Clearance Requirements	35
4.4 Installing the System	36
4.4.1 Mounting Battery Packs.....	36
4.4.2 Mounting the Inverter.....	41
4.4.3 Connecting Battery Packs	43
4.4.4 Connecting the Inverter and PV Solar Panels	49
4.4.5 Connecting to Grid and Loads.....	51
4.4.6 Connecting a Stick Logger	53
4.4.7 Connecting External CTs	54
4.4.8 Connecting a Smart Meter.....	55
4.4.9 (Optional) Connecting a Generator.....	58
4.5 Installing a Parallel System	58
4.5.1 Wiring of a Parallel System.....	58
4.5.2 Installation Prerequisites.....	59
4.5.3 Installation Procedure.....	60
5 COMMISSIONING.....	62
5.1 Checking Before Power-on.....	62
5.2 Powering On.....	62
5.3 Setting Common Parameters for the System	63
5.4 Checking the Settings.....	63
5.5 Powering off.....	64
6 SYSTEM OPERATION.....	66
6.1 Restarting the System	66
6.2 Viewing the Current System Information	66
6.3 Setting up the System	67

6.3.1	Go to SETUP	68
6.3.2	SYS SETTING	69
6.3.3	BAT SETTING	75
6.3.4	GRID STD.....	79
6.3.5	RUN SETTING	80
6.3.6	RS485 ADDRESS.....	90
6.3.7	BAUD RATE	90
6.3.8	LANGUAGE.....	91
6.3.9	BACK LIGHT	91
6.3.10	DATE/TIME.....	91
6.3.11	CLEAR REC	91
6.3.12	PASSWORD	92
6.3.13	MAINTENANCE.....	92
6.3.14	CT SELF CHK	93
6.4	Viewing INQUIRE	93
6.5	Viewing STATISTIC	94
6.6	Restoring Factory Settings (FCTRY RESET).....	95
6.7	Operating Battery Packs.....	95
6.7.1	Indicator Lights and States	95
6.7.2	Turning on a Battery Pack	98
6.7.3	Turning off a Battery Pack	98
6.7.4	Resetting a Battery Pack	98
6.7.5	Expanding Battery Capacity	98
7	MAINTENANCE	99
7.1	Inspection Checklist for Users	99
7.2	Inspection Checklist for Professional Personnel	99
7.3	Troubleshooting	100
7.3.1	Error Codes of the System	100
7.3.2	Alarm Codes of the System.....	104
7.3.3	BMS ALARM Warnings.....	107
7.3.4	BMS FAULT Warnings	108
7.3.5	BMS PROTECTION Warnings	110
8	STORING AND RECHARGING BATTERIES	115
8.1	Storage Environment Requirements	115
8.2	Interval for Recharging Batteries	115
8.3	Recharging a Battery	116
9	LIMITED WARRANTY	119
9.1	When the Warranty Period Starts and Ends.....	119
9.2	What This Warranty Covers.....	119
9.3	How to Obtain Warranty Service	119

9.4 Customer Responsibility for Warranty Service 119

9.5 Limitation of Liability 120

10 EMERGENCY PROCEDURE 121

10.1 General Handling..... 121

10.2 Potential Emergencies..... 121

 10.2.1 Battery Leakage..... 121

 10.2.2 Fire or Explosion..... 122

10.3 Emergency Handling Plan 123

11 DISPOSAL 124

12 SPECIFICATIONS 125

12.1 Hybrid Inverter 125

12.2 Battery Terminal Input/Output..... 126

12.3 PV Input..... 126

12.4 Grid Terminal Input/Output 127

12.5 Backup Load Terminal Output(Off Grid) 127

12.6 Backup Load Terminal Output (Grid-Tied)..... 128

12.7 Battery Pack (BP48100PF) 128

13 ABBREVIATIONS 130

14 APPENDIX: DEFINITION OF DVC 132

Legal Statement

All material appearing on this manual (“content”) is the property of Shenzhen Company Limited (“Company”). Distributing, copying, or forwarding any content to a third party or uploading any content to third-party platforms (such as publicly accessible websites) without prior permission of Company is expressly prohibited.

Trademarks and Permissions

All other trademarks or registered trademarks are the property of their respective owners.

Software License

Company reserves all rights to the firmware and software. You may not use any of the data in the firmware or software for commercial purposes in any way.

Reverse engineering, decompiling, disassembling, adapting, implanting, or other derivative operations on the equipment are prohibited, as are researching the design and implementation of the equipment, obtaining the source code, infringing on intellectual property rights in any way, and disclosing the results of any performance tests.

Disclaimer

Before transporting, storing, installing, using, and/or maintaining the equipment, read this manual, adhere strictly to its prescriptions, and pay attention to the labels on the equipment.

In this manual,

- “Equipment” refers to the hardware products, firmware, software, components, spare parts, and/or services to which this manual relates.
- “You” or “your” refers to an individual or a legal entity transporting, storing, installing, using, and/or maintaining the equipment.

In addition to paying proper attention to content in this manual labelled DANGER, WARNING, CAUTION, and NOTICE, you shall comply with relevant international, national, or regional standards, and industry practices. Company shall not be liable for any damages resulting from violations of safety requirements or safety standards for the design, manufacturing, and use of the equipment.

Company is not responsible for damage, personal injuries, death, and/or loss of or damage to property caused by use outside the scope of the conditions, technical specifications, or instructions provided in this manual.

Transport, storage, installation, use, maintenance, and all other operations shall comply with applicable laws and regulations, standards, and specifications.

Company shall bear no liability in any of the following circumstances:

- The equipment is damaged due to earthquakes, floods, volcanic eruptions, mudslides, lightning strikes, fires, wars or armed conflicts, typhoons, hurricanes, tornadoes, extreme

weather, or other force majeure events.

- The equipment is used outside the scope of the conditions, technical specifications, or instructions provided in this manual.
- Installation and/or use do not comply with relevant international, national, or regional standards or regulations.
- The equipment is installed or operated by unqualified personnel.
- The equipment is operated in a manner not in accordance with the prescriptions of the instruction manual and safety labels.
- The equipment and/or software code is disassembled and/or modified without the permission of Company.
- The equipment is damaged while being transported by you or a third party commissioned by you.
- The equipment is stored in conditions that do not meet the standards specified in this manual.
- In the course of operating or maintaining the equipment, you use your own materials and tools that do not meet the requirements of local laws, regulations, and standards.
- Damage is caused by you or a third party through negligence, willful misconduct, gross negligence, or mishandling, or for other reasons not attributable to Company.

1 About This Manual

This manual contains important information on the transport, storage, installation, use, and maintenance of the equipment. Read this manual carefully before operation. You must use the equipment strictly in accordance with the instructions in this manual to prevent damage or loss to the equipment, persons, and/or property. Keep this manual for future reference.

1.1 Purpose

This manual is intended as:

- An introduction to a split-phase hybrid inverter (the E8KD/E10KD/E12KD/E15KD), and the BP48100PF lithium-ion battery pack.
- An installation and maintenance guide for qualified personnel and technicians working with the hybrid inverters and the battery packs.
- An operating guide for qualified personnel, technicians, and users of the energy management system (EMS) integrated in the hybrid inverter.

This manual does not include information on all the components in a photovoltaic system. For more information, visit the websites of the component manufacturers.

1.2 Intended Audience

The intended audience of this manual is:

- The qualified professional personnel and technicians who install, operate, and maintain residential photovoltaic energy storage systems that include an E8KD/E10KD/E12KD/E15KD hybrid inverter, and/or the BP48100PF battery pack.
- Users who need to view inverter parameters.
- System integration solution providers.

1.3 Conventions

The following symbols are used in this manual to highlight important information.



Indicates a hazardous situation that, if not avoided, will result in death or severe injury.



Indicates a hazardous situation that, if not avoided, could result in death or severe injury.



Indicates a hazardous situation that, if not avoided, could result in minor or moderate injury.



Indicates information that is considered important but is not hazard related, typically used for activities that result in property damage, but no personal injury.



Indicates an important tip that leads to the best results, but not safety or damage related.

1.4 Change History

Here is the change history of this manual.

Version	Date	Changes
1.0	Dec-2024	• Initial release.

2 Safety Instructions

All the safety instructions in this section help you transport, store, install, use, and maintain the equipment safely, so be sure to read and follow them. In addition to these safety instructions, you must comply with the requirements of international, national, or regional standards and regulations, and you are encouraged to follow industry best practices.

The equipment must be transported, installed, and maintained by trained professionals who fully understand how the equipment works, have sufficient training and experience in operating the equipment, and know the possible dangers and their levels. Trained personnel are those who have received relevant technical and safety training and have relevant experience. They know the possible dangers they may face when operating the equipment and how to take steps to minimize the dangers to themselves and others.

2.1 Limitation of Liability

Company is not responsible, directly or indirectly, for any damage to the equipment or loss of property caused by the following:

- Disassembling and/or modifying the equipment, replacing parts, or modifying the software code without the permission of the manufacturer.
- Altering, repairing, and erasing serial numbers or seals by technicians not certified by the manufacturer.
- Installation and/or operation of the equipment by unqualified personnel.
- Installing the inverter in any way that does not comply with standards or regulations.
- Failure to comply with local safety regulations. For example, in Germany, equipment must comply with VDE certification and in Australia it must comply with SAA certification.
- Operation of the equipment in an environment with insufficient ventilation.
- Use not in accordance with the instruction manual, technical specifications, and/or any other instruction provided.
- Use of your own materials and tools that do not meet the requirements of local laws, regulations, and standards.
- Failure to follow standard maintenance procedures.
- Earthquakes, floods, volcanic eruptions, mudslides, lightning strikes, fires, wars, armed conflicts, typhoons, hurricanes, tornadoes, extreme weather, or other force majeure events.

Additionally, Company is not responsible, directly or indirectly, for:

- Damage sustained during transportation, including paint scratches caused by friction inside the package during transportation, and damage sustained while being transported by you or a third party commissioned by you. You must file claims with the shipping or insurance company when the container and/or the package is unloaded and the damage is confirmed.

- Any other damage caused by you or a third party through negligence, willful misconduct, or mishandling, or for other reasons not attributable to Company.

2.2 Warning Signs

The warning signs and nameplates attached to the equipment contain important information to guide you in safe use of the equipment. DO NOT remove, obscure, or damage these signs. Make sure that these signs are always intact and fixed in their correct positions. If a warning sign is damaged, contact the manufacturer and have it replaced immediately by certified technicians.

You can see these warning signs attached to the equipment.



Indicates a hazardous situation that, if not avoided, can result in death or severe injury!



Indicates that the inverter should NOT be touched or used for at least five minutes after it is turned off or disconnected, in order to prevent electric shock or personal injury.



Indicates a hot surface. Contact can cause burns.



Indicates that you should read the user manual for instructions.

WARNING

After the equipment is unpacked,

- Check all the warning signs and nameplates on the equipment.
- If you find any damages to the warning signs and/or nameplates on the equipment, contact the manufacturer immediately and DO NOT install the equipment.

WARNING

Before disposal, make sure that all warning signs and nameplates are clearly visible and are not removed or obscured.

WARNING

When you instruct others in use of the equipment, and maintain and/or repair the equipment, follow these instructions to prevent inappropriate use or accidents caused by uninvolved persons:

- Place clear signs at the front and rear-level switches to prevent accidents caused by inappropriate switching.
- Place a warning sign or safety caution tape around the operating area.

2.3 Battery Safety

A rechargeable lithium-ion phosphate battery is used in the equipment. The battery complies with the provisions of “United Nations Recommendations on the Transport of Dangerous Goods, Manual of Tests and Criteria, Part III, Section 38.3”.

Company shall not be responsible for:

- Damages to the battery caused by earthquakes, floods, volcanic eruptions, mudslides, lightning strikes, fires, wars, armed conflicts, typhoons, hurricanes, tornadoes, extreme weather, or other force majeure events.
- Direct damage caused by operation of the equipment in environments other than the intended operating environment. Indicators of inappropriate environments include, but are not limited to, excessively high or low operating temperatures, instability of the power grid, and frequent power outages.
- Damage, leakage, and/or rupture caused by inappropriate operation or failure to connect the battery pack in accordance with requirements.
- Damage caused by over-discharge of the battery due to the failure of operating personnel to promptly power up the battery after it has been connected to the system.
- Damage caused by your failure to accept the battery in time after installation.
- Damage caused by inappropriate parameters that you set.
- Accelerated battery capacity degradation caused by mixing of batteries, including, but not limited to, the mixing of batteries of different brands and mixing of batteries with different rated capacities.
- Battery damage caused by storing the battery in an unintended environment, such as in a humid, rain-prone environment.
- Loss of capacity or irreversible damage to the battery caused over-storage without recharging the battery in a timely manner.
- Damage caused by your or a third party’s failure to follow the requirements specified by the manufacturer, including, but not limited to, unauthorized relocation and installation of the battery packs.

Company shall not be responsible for damage caused by:

- Frequent over-discharge of batteries caused by your inappropriate maintenance, on-site expansion, or long-term failure to fully charge.
- Lack of appropriate maintenance in accordance with the operating manual. Such battery maintenance should include, but is not limited to, regular checks of the battery terminal screws to verify tightness.
- Changing the battery usage scenario without the approval of the manufacturer.
- Unapproved connection of additional loads to the battery.
- Batteries exceeding the maximum storage life.
- Batteries exceeding the warranty period. Such batteries can pose hazards and it is not recommended that you continue to use them.

2.3.1 General Instructions

The chemical substances inside the battery are well sealed, so there is no physical danger of fire or explosion or chemical danger of hazardous material leakage at normal temperatures and pressure levels during handling. If the battery pack is exposed to fire, mechanical shock, decomposition, or increased electrical stress due to misuse, then leakage, release of harmful substances, and/or explosion can occur. The released substances can irritate the eyes, skin, and throat.



DANGER

- Only trained professionals are permitted to handle leaking batteries.
- When handling leaking batteries, personnel must wear goggles, rubber gloves, gas masks, and protective clothing.
- When handling leaking batteries, personnel must first disconnect the equipment and then remove the leaking batteries.
- Batteries should be protected from the following:
 - Short circuit caused by live line maintenance or by shorting the positive and negative terminals of the battery.
 - Exposure to high temperature or heating equipment, such as direct sunlight, ignition sources, transformers, or heaters.
 - Squeezing by an external force or immersion in water or other liquids.
 - Over-charging or forced over-discharging.
 - Exposing battery terminals to other metal objects.
 - The use of incorrect battery types.



WARNING

Batteries should be protected from the following:

- Malfunctions or short circuits caused by liquid entering the battery. Therefore, DO NOT install the battery pack under air conditioning outlets, ventilation vents, machine room outlet windows, water pipes, and other locations prone to water leakage.
 - Inverted, sideways, tilted, or stacked placement.
 - False connection of fastening screws of the copper row and/or the cable, which can cause excessive voltage drop or the generation of a large amount of heat at higher current, which could burn the battery.
-

2.3.2 Maintenance of Battery Packs

 **DANGER**

- DO NOT perform live line maintenance on the batteries to prevent short circuit.
- Use the specified type of battery during replacement.

 **WARNING**

- Do a regular check on the fastening screws of copper rows and/or cables. Make sure that they are tightened and free of rust, corrosion, or other foreign objects. If they are not, clean them.
-

2.3.3 Disposal of Battery Packs

 **WARNING**

- Before disposal, completely discharge the battery and consume the lithium metal inside the battery.
 - DO NOT treat unwanted batteries as ordinary waste.
 - DO NOT throw the battery pack into fire or place them in high temperature.
 - DO NOT dissect, pierce, or crush the batteries.
 - If a battery pack is deformed, broken, or leaking, discard it immediately regardless of how long it has been in storage.
-

2.4 Before Installation



- Follow the safety instructions in this manual to prevent personal injury and/or property damage.
 - During transportation, a certified ABC fire extinguisher with a capacity of at least 2 kg must be with the equipment.
 - Smoking is not permitted on or near the vehicle while loading or unloading.
 - Before installation, make sure that the equipment is free of any electrical connections.
 - Make sure that no water pipes are inside the wall on which the system is to be mounted.
 - To prevent possible electric shock, make sure that the inverter is not damaged and that the inverter and all switches connected to it are set to the “OFF” position.
 - Before installation, use a properly calibrated voltage meter to test the inverter to prevent personal injury or damage caused by a life-threatening voltage.
 - The PV string exposed to sunlight can generate high voltage. Do these to prevent personal injury:
 - The operator must wear personal protective equipment before electrical connection.
 - Before touching DC cables, use a measuring device to make sure that the cables are not energized.
 - Read the safety instructions attached to the PV string and its manuals.
 - DO NOT connect the inverter to a PV string that requires positive or negative grounding.
-

 WARNING

- DO NOT transport equipment in severe weather such as lightning, rain, snow, or winds of force 6 or higher.
- If there is a fire, evacuate the building or equipment area and ring the fire alarm. DO NOT enter a burning building or equipment area.
- Choose an appropriate and safe place to install the equipment. This place must meet these requirements:
 - Temperature: For the inverter and battery pack. See [Specifications](#).
 - Relative humidity: 0–95% (No condensation).
 - NO flammable or explosive materials.
 - NOT accessible to children.
 - NO salt hazards.
 - Sheltered from direct sunlight or severe weather.
 - NOT subject to strong vibration or electromagnetic fields.
 - Well ventilated
 - NOT a living area.
- A distance of at least 30 mm must be maintained between the cable and a heat generating device or the periphery of a heat source area to prevent deterioration and/or breakage of the cable insulation caused by high temperature.
- DO NOT install the equipment that is infiltrated by moisture.
- DO NOT install the equipment with damaged enclosure and exposed to moisture.

 CAUTION

- Only qualified personnel are permitted to transport the equipment.
- Loading, unloading, installation, removal, and transportation of inverters and battery packs must be accomplished by two or more persons to prevent personal injury caused by accidental falling equipment.
- If lifting tools are used to lift the equipment, make sure that no one passes or stays under the equipment.

NOTICE

- Before installation, do a regular check and maintenance on the tools.

2.5 Installation Safety



- To avoid personal injury caused by the high voltage inside the equipment:
 - Use special insulated tools for wiring.
 - Read the warning signs on the equipment and follow their instructions.
 - Follow the safety instructions in this manual and other documents provided.
 - Only trained professionals are permitted to install the equipment.
 - Only qualified personnel are permitted to disassemble the safety features and to service the equipment.
 - Only the personnel who have the special operation qualification required by national or local authorities are permitted to work in special scenarios such as electrical operation, work at heights, and operation of special equipment.
 - Only KSTAR-approved professional personnel are permitted to replace the equipment or spare parts (including software).
 - DO NOT power up the equipment before the installation is completed and confirmed by trained professionals.
 - Avoid direct contact with the power supply equipment, as well as indirect contact through wet objects. Prevent other conductors from coming into contact with the power supply equipment. Measure the voltage at the point of contact before you touch any conductor surface or terminal, so as to avoid electric shock.
 - Use appropriate measuring tools to make sure that the electrical parameters of the equipment meet the requirements. To prevent electric arcs or shocks, make sure that the connection and use of the equipment comply with the specifications.
-

 **WARNING**

- DO NOT install equipment in severe weather such as lightning, rain, snow, or winds of force 6 or higher.
- If there is a fire, evacuate the building or equipment area and ring the fire alarm, or call the emergency services. DO NOT enter a burning building or equipment area.
- It is recommended that you install the inverter vertically, not inverted, horizontal, tilted forward or backward, excessively tilted, or tilted sideways.
- When tightening screws or bolts on products or terminals with tools, tighten to the specified torque to prevent damage to the equipment. The manufacturer shall not be responsible for such damage.
- DO NOT touch the equipment surface when the equipment is in operation. The housing gets hot, and touching it can result in burns.
- The cables used in the PV system must be of the right size, firmly connected, and well insulated.
- Before connecting the DC connector to the inverter, check the positive and negative terminals of the PV string and make sure that no error occurs before inserting the DC connector into the DC terminal.
- During the installation of the inverter, make sure that neither the positive nor the negative terminal of the PV string is shorted to ground, to prevent damage caused by AC/DC short circuit of the inverter.

 **CAUTION**

- To prevent uninvolved persons from approaching the equipment, place highly visible warning signs or set up safety caution tape around the equipment.
- DO NOT remove the equipment protection.
- DO NOT ignore the danger, warning, caution, and notice text in the manuals and on the equipment.

NOTICE

- The wiring process must follow the regulations of the local grid and the safety instructions for the PV string.

2.6 Operation Safety



- Follow the safety instructions in this manual to prevent personal injury and/or property damage.
 - The person who operates the equipment must have necessary knowledge of the equipment, including the equipment components and how they work.
 - The person who operates the equipment must have necessary knowledge of this manual.
 - Only qualified personnel are permitted to disassemble the safety features and to service the equipment.
 - Keep persons other than those operating the equipment away from the equipment.
 - DO NOT operate the equipment in an environment where explosions can occur, or where the relative humidity is high.
 - When the equipment is in operation,
 - DO NOT open the inverter and the battery packs.
 - DO NOT wipe the equipment with a wet cloth.
 - DO NOT touch the housing of the equipment.
 - DO NOT plug or unplug connectors on the inverter.
 - To avoid electric shock, DO NOT touch any terminals of the inverter.
 - To avoid electric shock, DO NOT disassemble any parts of the inverter.
 - To avoid burns, DO NOT touch any hot parts of the inverter, such as radiator.
 - To avoid electric shock, DO NOT connect or disconnect a PV string or a component of a PV string.
 - To avoid fatal electric shock, DO NOT touch the DC conductors or energized electrical parts of the inverter. When PV arrays are exposed to sunlight, they can generate life-threatening DC voltage. This voltage can be present in DC conductors and in the energized electrical parts of the inverter.
 - To avoid electric shocks and burns caused by possible arcs, DO NOT disconnect the DC connector from the inverter under load.
 - Before operating the inverter or the battery packs, disconnect the inverter from all voltage sources as described in this manual.
 - DO NOT touch uninsulated cable ends.
-

- To prevent chemical burns caused by leakage of electrolyte or toxic gases from a damaged battery, operate the battery packs in accordance with the standard procedure. When the battery packs are operated in a standard manner, no leakage of electrolyte or generation of toxic gases can occur. However, if the battery packs are damaged or malfunction, it can leak electrolyte or generate toxic gases.

 **WARNING**

- DO NOT operate equipment in severe weather such as lightning, rain, snow, or winds of force 6 or higher.
- DO NOT touch the equipment with wet hands.
- DO NOT put any heavy objects on the top of the equipment.
- DO NOT damage the equipment with sharp objects.

 **CAUTION**

- To prevent uninvolved persons from approaching the equipment, place highly visible warning signs or set up safety caution tape around the equipment.
- DO NOT move the inverter when it is connected to the battery packs.
- Secure the inverter to prevent tilting.
- During the operation of the equipment, if any risks are found that may lead to personal injury or equipment damage, stop the operation immediately, report to the person in charge, and take effective steps.
- During the operation of the inverter, make sure that neither the positive nor the negative terminal of the PV string is shorted to ground, to prevent damage caused by AC/DC short circuit of the inverter.

NOTICE

- In the event of exposure to the electrolyte, immediately flush the affected area with water and seek immediate medical attention.
-

2.7 Maintenance Safety

 **DANGER**

- Follow the safety instructions in this manual to prevent personal injury and/or property damage.
- Only trained professionals are permitted to maintain the equipment.
- Only qualified personnel are permitted to disassemble the safety features and to service the equipment.
- Keep persons other than those operating the equipment away from the equipment.
- Wear personal protective equipment (PPE), including protective gloves and protective shoes.
- DO NOT begin maintenance work on the equipment until it is turned off and fully discharged.
- Before maintenance, disconnect the AC circuit breaker from the grid and check the inverter status. If all the inverter indicator lights are off, do nothing and disconnect the DC switch at night. If the inverter indicator is on, disconnect the DC switch directly.
- After the inverter is powered down for five minutes, use testing equipment to check the voltage of the bus capacitor and of the capacitors in the battery terminal input and make sure that there is no voltage.
- To avoid burns, DO NOT operate the equipment immediately after shutdown. After the equipment cools down, wear protective gloves to operate the equipment.

 **WARNING**

- DO NOT maintain equipment in severe weather such as lightning, rain, snow, or winds of force 6 or higher.
 - To avoid electric shock, DO NOT touch the power grid or the contacts and terminals inside the equipment that are connected to the grid.
 - Use a standard voltmeter to check the grid. DO NOT touch the grid before you make sure that there is not voltage.
 - To prevent or to minimize potential damage caused by moisture, DO NOT repair or maintain the equipment in a wet environment.
-

 WARNING

External protective earthing terminal shall meet at least one of the following requirements:

- When the cross-sectional area of the earthing cable is $\geq 10\text{mm}^2$ (copper) or $\geq 16\text{mm}^2$ (aluminum), it is recommended that both the external protective earthing terminal and the AC side earthing terminal are grounded.
- When the cross-sectional area of the earthing cable is $< 10\text{mm}^2$ (copper) or $< 16\text{mm}^2$ (aluminum), **ensure that** both the external protective earthing terminal and the AC side earthing terminal are grounded.

If alternative earthing methods comply with local standards and relevant safety regulations, the connection may be performed according to such standards and regulations. Our company shall not be held liable for any consequences that may arise therefrom.

 CAUTION

- To prevent uninvolved persons from approaching the equipment, place highly visible warning signs or set up safety caution tape around the equipment.

NOTICE

- If the paint on the inverter housing falls off or rust appears, repair it in a timely manner. Otherwise, the user manufacturer.

2.8 Disposal Safety

 DANGER

- Only trained professionals are permitted to discard the equipment.

 WARNING

- Before disposal, make sure that all warning signs and nameplates are clearly visible and have not been removed or obscured.
- To prevent property damage and personal injury, dispose of equipment in accordance with local regulations and standards.

3 Product Introduction

3.1 Features

The E8KD/E10KD/E12KD/E15KD is a residential photovoltaic storage system that is composed of a power control module and an extendable battery pack. It stores and releases electrical energy according to the inverter management system requirements. Company provides a photovoltaic storage-monitoring platform to monitor and control electricity generation and storage of the E8KD/E10KD/E12KD/E15KD. Power generation, consumption, and storage can be grasped at any time and any place, and the information can be monitored and controlled remotely. The E8KD/E10KD/E12KD/E15KD comes with an integrated energy management system (EMS). This system enables the inverter to run off-grid or on-grid and manages energy flow intelligently so that the system can operate economically.

3.2 Delivery Scope

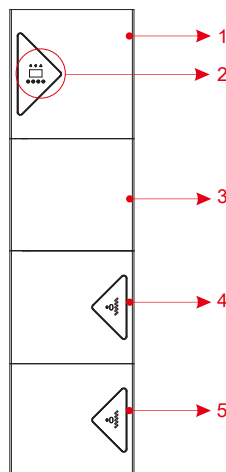

Figure 3-1 E8KD/E10KD/E12KD/E15KD Delivery Scope

- 1 Hybrid Inverter
- 2 EMS Display Screen
- 3 Inverter distribution box
- 4 Battery PACK (Battery 1)
- 5 Battery PACK (Battery 2)

3.3 Model

3.3.1 Inverter Model

The hybrid inverter model is E8KD/E10KD/E12KD/E15KD.

E	xK	D
<u>1</u>	<u>2</u>	<u>3</u>

- 1 “E” means “energy storage system”.
- 2 “xK” indicates the rated output of the system. “8K” means 8 kW, “10K” means 10 kW, and “12K” means 12 kW “15K” means 15 kW.
- 3 “D” means “split-phase inverter”.

3.3.2 Battery Pack Model

The battery pack model is BP48100PF.

BP	48	100	P	F
<u>1</u>	<u>2</u>	<u>3</u>	<u>4</u>	<u>5</u>

- 1 “BP” means the name of the product series.
- 2 “48” means the voltage of the battery.
- 3 “100” means the battery capacity is 100Ah.
- 4 “P” means the low voltage parallel. If it is “S”, it means series output of high voltage.
- 5 “F” means with a heating film. If it is empty, it means without a heating film.

3.4 Inverter Appearance

Here is the appearance of the inverter with the uncovered cable box. You can use the integrated EMS on the LCD screen to set up the system.

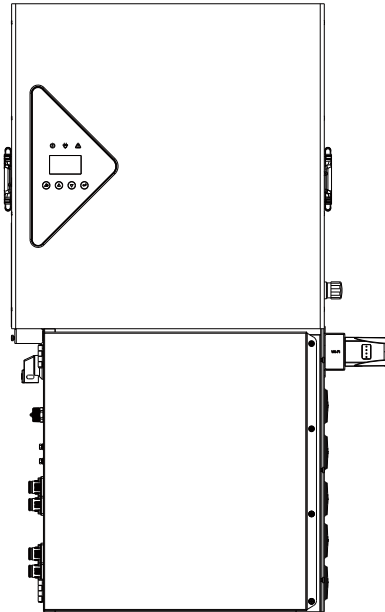





Figure 3-2 Inverter -Front View

3.4.1 LCD Screen

You can use the LCD screen (A) on the inverter to operate the integrated EMS.

-
-  Indicator light. When this indicator light is on, the inverter is connected to the grid. When this indicator light is blinking and the other indicator lights are off, the inverter is running and grid power is bypassed.

 -  Indicator light. When this indicator light is on, the inverter runs off-grid.

 -  Indicator light. This indicator light turns on (red) when a fault has occurred.

 -  Button. On the home page, press this button to go to the USER page to change the settings. You can press this button to leave the current page.

 -  Button. Press this button to move the cursor up or to increase the setting value.

 -  Button. Press this button to move the cursor down or to decrease the setting value.

 -  Button. Press this button to confirm the selection. When the LCD screen shows the current system information in turn automatically, you can press this button to lock the screen to show one page of information.
-

3.4.2 Breaker and terminal

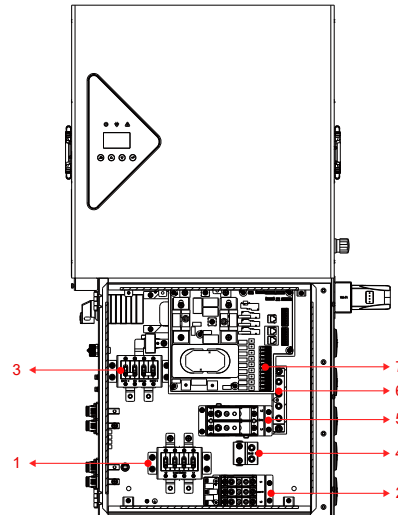

Figure 3-3 Inverter distribution box

- | | |
|---|------------------------------|
| 1 BACK UP breaker | 5 Grid terminal block |
| 2 Output terminal block(BACK UP) | 6 PE terminal block |
| 3 Battery circuit breaker | 7 PV terminal block |
| 4 Grid N terminal block | |

3.4.3 Ports

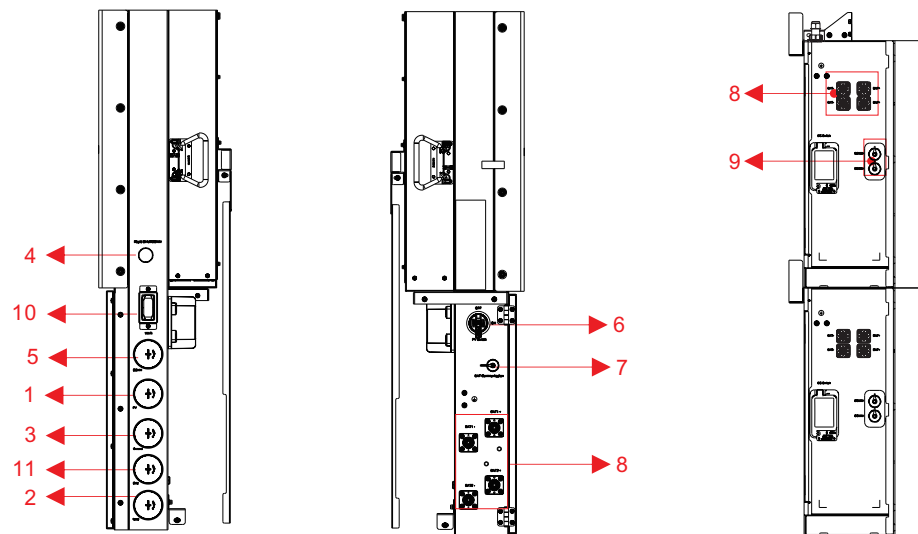

Figure 3-4 Inverter Ports

- | | |
|---------------------------------------|-----------------------------------|
| 1 PV cable hole (DVC C) | 7 BAT Communication(DVC A) |
| 2 BACKUP cable hole(DVC C) | 8 BAT+,BAT-(DVC A) |
| 3 PE cable hole(DVC A) | 9 COM (DVC A) |
| 4 Rapid shutdown button(DVC A) | 10 Wi-Fi(DVC A) |
| 5 COM cable hole(DVC A) | 11 GRID cable hole(DVC C) |
| 6 PV switch(DVC A) | |



Decisive voltage classification (DVC) identifies the minimum necessary level of protection for the circuit. For more information on the DVC of each port, see [Appendix: Definition of DVC](#).

3.5 Battery Pack Appearance

BP48100PF

Figure 3-5 shows the appearance of the BP48100PF.

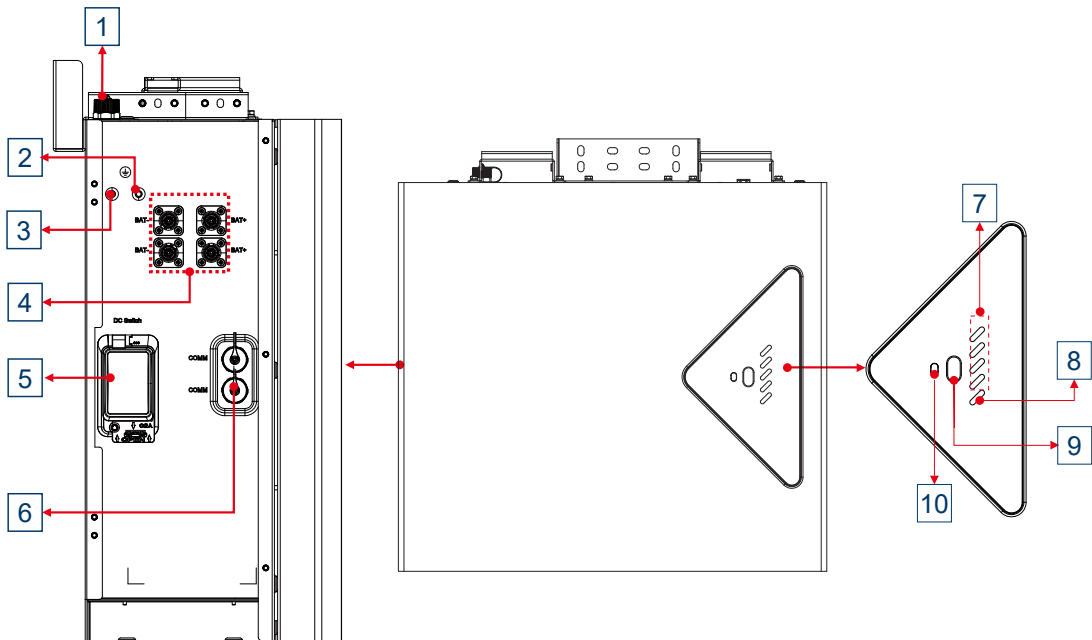

Figure 3-5 Appearance of BP48100PF

- 1 INV. Used for communication between the inverter and the battery pack.
- 2 PE1 3 PE2 4 BAT+ and BAT- 5 DC Switch
- 6 COMM. Supports RS485 communication only.

7 The SOC indicator lights, composed of four indicator lights, work in conjunction with the **FAULT** light and the **OPERATION** light to show the states of the battery pack. For more information, see [Indicator Lights and States](#) of battery packs.

8 The **FAULT** indicator light works in conjunction with the SOC lights and the **OPERATION** light to show the states of the battery pack. For more information, see [Indicator Lights and States](#) of battery packs.

- The **OPERATION** indicator light works in conjunction with the SOC lights and the **FAULT** light to show the states of the battery pack. For more information, see [Indicator Lights and States](#) of battery packs.

- Reset Button. Press the button to start, dormancy, and reset the battery pack. For more information, see [Turning on a Battery Pack](#), [Turning off a Battery Pack](#), and [Resetting a Battery Pack](#).

3.6 Energy Management System (EMS)

The inverter incorporates an electric energy management system (EMS) for low-voltage power distribution systems. It is an extended development of the energy management system that complies with the standard specifications of the power distribution system. It is highly automated, easy-to-use, high-performance, and highly reliable. You can use this system on the LCD screen on the inverter to deploy loads, optimize operation, and effectively save power.

3.7 Parallel System

With the E8KD/E10KD/E12KD/E15KD, you can connect up to four inverters of the same model in parallel to build a parallel system. In a parallel system, loads must be connected in parallel on both the on-grid and backup sides. Compared with a system installed with one inverter, a parallel system expands the system capacity. For example, the rated power of the on-grid side of a system installed with one E10KD is 10 kW, but the rated power of the on-grid side of a parallel system with three E10KDs is 30 kW ($= 3 \times 10 \text{ kW}$). The rated power of the backup side is calculated in the same way.

To build a parallel system, you must set one inverter as the primary inverter, and others as subordinate inverters. For more information, see [Installing a Parallel System](#).



- In a parallel system, the LCD screen on each inverter shows the total grid power and total normal load power of the system.
- In a parallel system, for some settings, such as working mode, zero export, and time setting of the PEAK SHIFT mode, you only need to set them in the primary inverter. These settings in the subordinate inverters are to be forced to synchronize with the primary inverter, but the setting values shown on the LCD screens of the subordinate inverters do not automatically change in synchronization.
- In a parallel system, all settings must be the same for all inverters except for the addresses of the inverters.

3.8 Scenarios

The E8KD/E10KD/E12KD/E15KD can be used in both a DC-coupling system and an AC-coupling system.

3.8.1 DC-coupling System

In a DC-coupling system, the DC electricity generated by the PV panels is directly sent to and stored in the batteries through the inverter. A DC-coupling system is ideal for a new on- and off-grid solar+storage system installation.

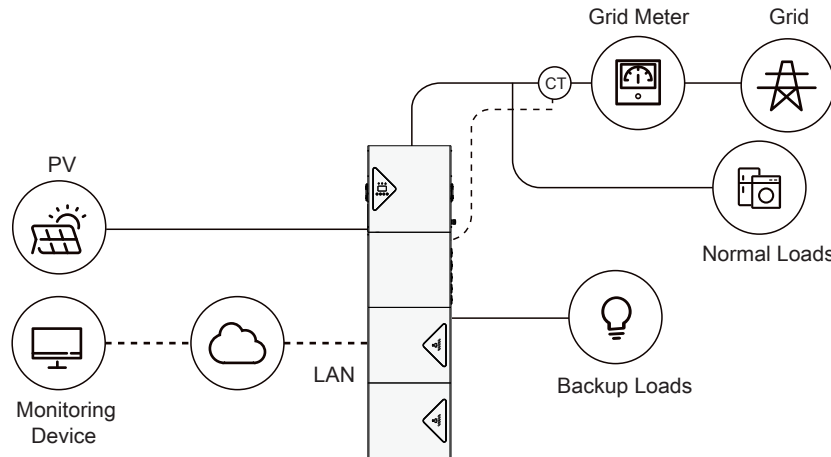

Figure 3-6 DC-coupling System

Here is the single line diagram of a DC-coupling system.

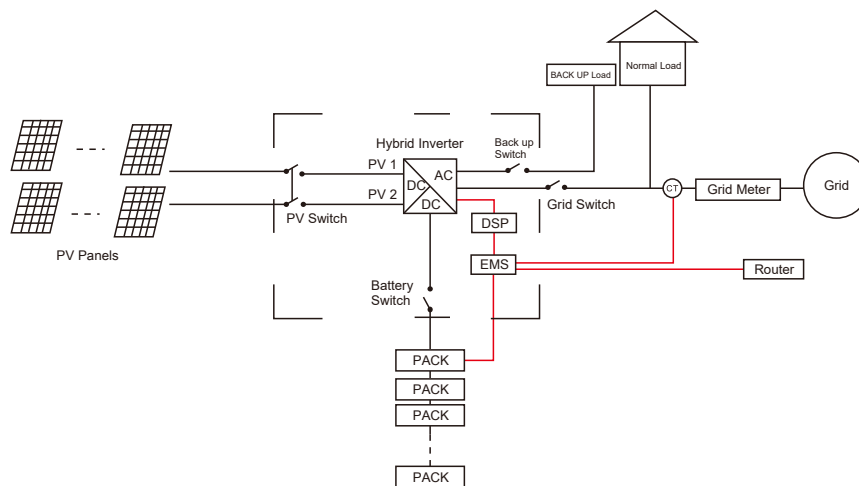

Figure 3-7 Single Line Diagram, DC-coupling System

3.8.2 AC-coupling System

In an AC-coupling system, DC electricity flows from PV panels to the inverter, the AC electricity from the inverter flows to the household loads or other inverters to transform the AC electricity back to DC electricity, and then store it in the batteries. An AC-coupling system is ideal for retrofit.

The E8KD/E10KD/E12KD/E15KD supports two AC-coupling system schemas.

If you already have a PV inverter and now want to add an energy storage system to the inverter, but no PV panel is available for connection, you can use AC-coupling system Schema 1.

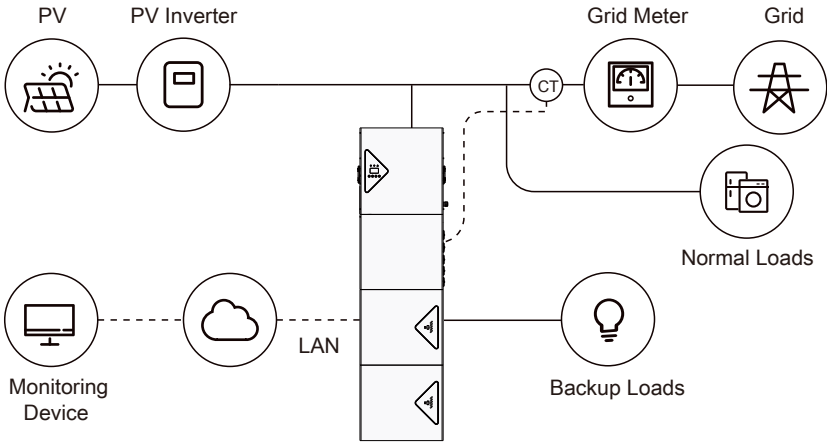

Figure 3-8 AC-coupling System, Schema 1

Here is the single line diagram of an AC-coupling system Schema 1.

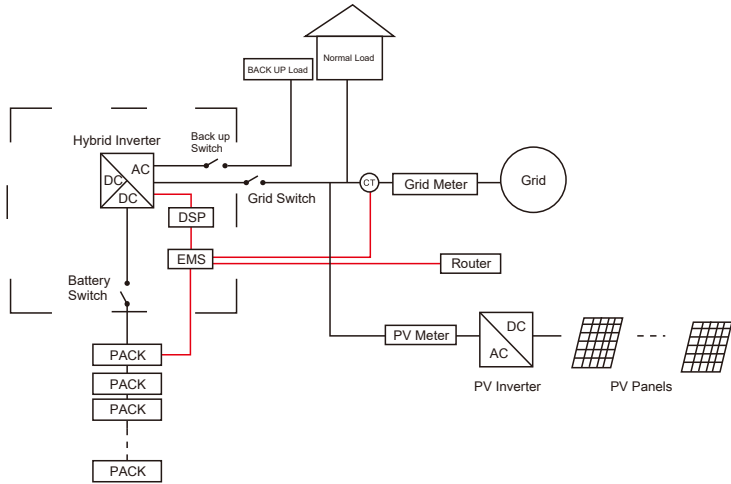

Figure 3-9 Single Line Diagram, AC-coupling System Schema 1

If you already have a PV inverter, now want to add an energy storage system to the inverter, and a PV panel is available for connection, you can use Schema 2 of AC-coupling system.

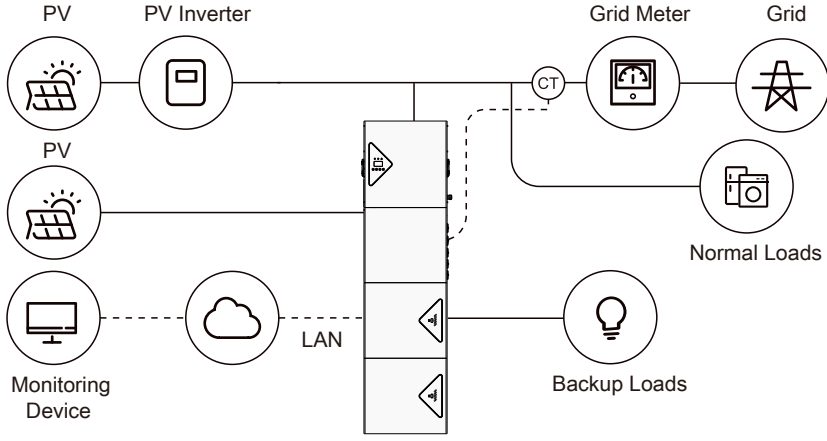

Figure 3-10 AC-coupling System, Schema 2

Here is the single line diagram of an AC-coupling system Schema 2.

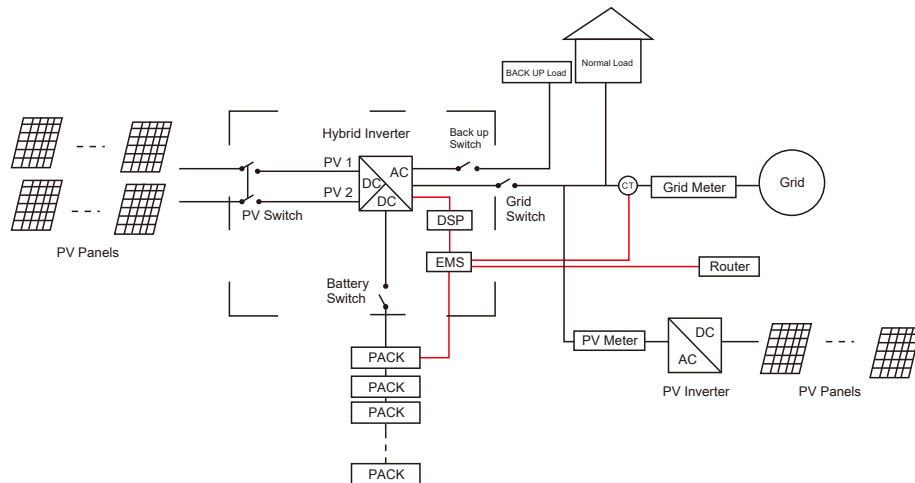

Figure 3-11 Single Line Diagram, AC-coupling System Schema 2

3.9 Wiring Diagram

NOTICE

Make sure that the grounding resistance is less than 10 Ω.
 Make sure that the grounding of the backup load is correct and tightened.
 Otherwise, during a grid failure, the backup may not function normally.

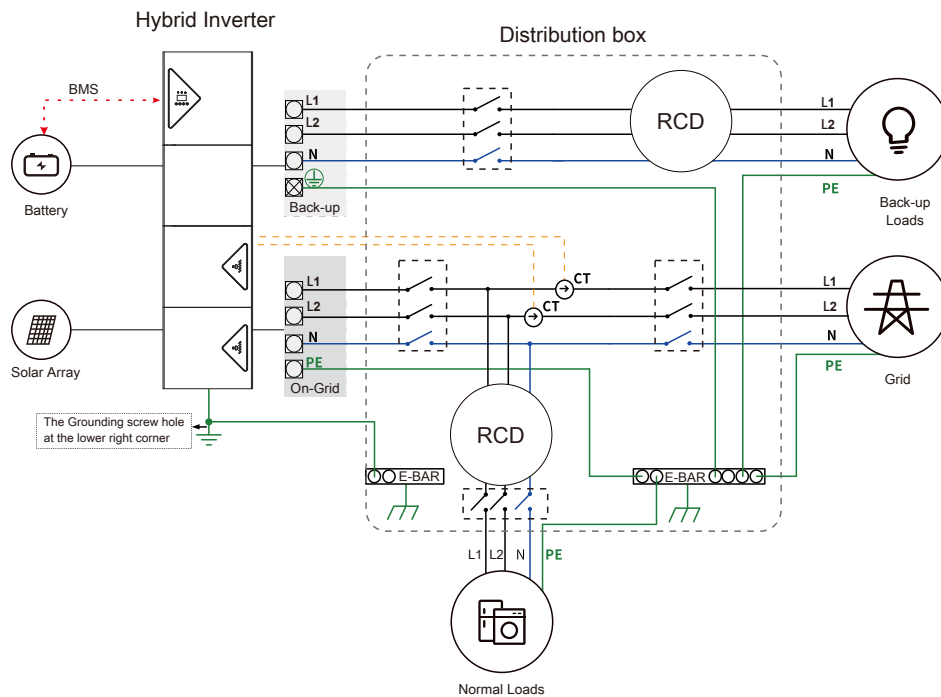

Figure 3-12 Wiring Diagram

3.9.1 Rapid Shutdown Device

The models of rapid Shutdown Device used with inverters are AP Smart

RSD-D-20. The device must be installed at the output of the photovoltaic plate. The installation diagram is shown in Figure 3-13.

RSD-D



Figure 3-13 Rapid Shutdown Device installation diagram

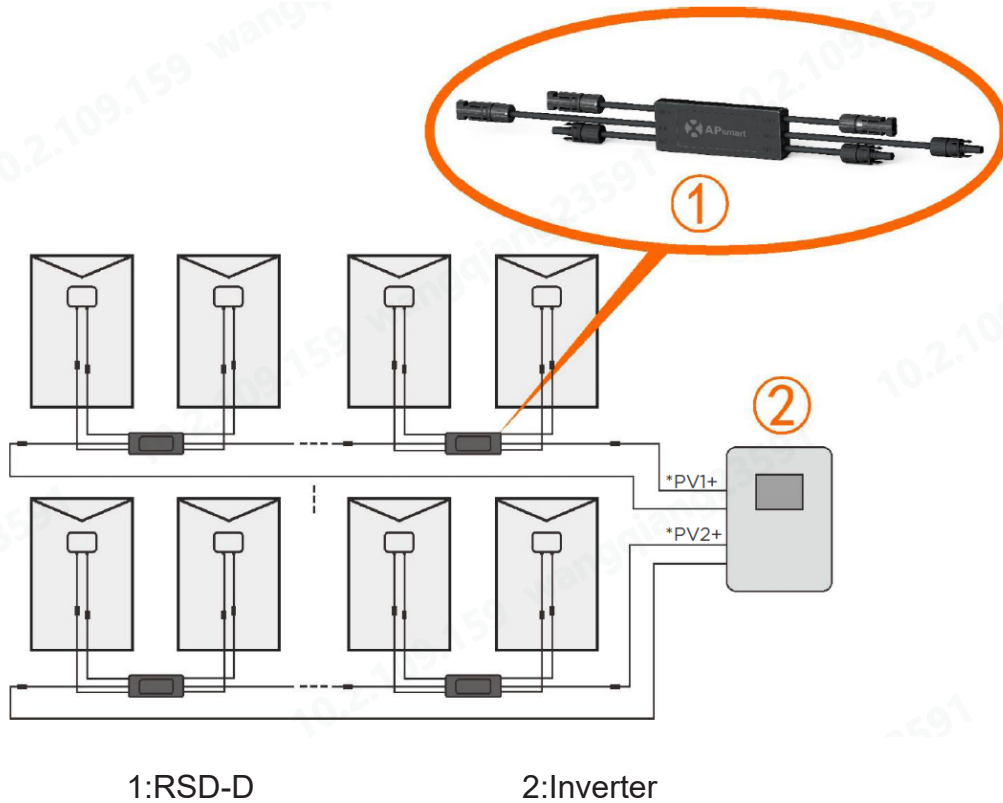

Figure 3-14 Rapid Shutdown Device installation diagram

Inverter includes an integrated SunSpec-certified Rapid Shutdown Transmitter, After pressing the inverter rapid shutdown button, RSD-D will cut off the photovoltaic plate in about 30s.





3.10 System States

3.10.1 Inverter States

The inverter can be in three states shown in Table 3 1.

Table 3-1 Inverter States

State	Description
-------	-------------

RUNNING	Generally, when the inverter is powered on, the inverter is in the RUNNING state. When the inverter is connected to the grid, the  light on the LCD screen is on. When the inverter is not connected to the grid, the  light on the LCD screen is on.
FAULT	When an error code is shown, the inverter is in the FAULT state and the  light turns on. When the error code is cleared, the  light turns off and the inverter returns to the RUNNING or IDLE state.
SHUTDOWN	When the inverter is powered off, it is in the SHUTDOWN state. All indicator lights on the LCD screen are off.



For more information about the error codes, see [Error Codes of the System](#) and [Alarm Codes of the System](#).

3.10.2 Battery Pack States

A battery pack can be in five states: OFF, NORMAL, ALARM, FAULT, and PROTECTION. For more information, see [Indicator Lights and States](#).

3.11 Working Modes

The E8KD/E10KD/E12KD/E15KD supports three working modes: SELF CONSUME, BAT PRIORITY, and PEAK SHIFT. You can choose a working mode through the integrated EMS. For more information, see the [WORK MODE](#) subsection under [SYS SETTING](#).

3.11.1 SELF CONSUME

In SELF CONSUME mode, the electricity generated by the PV panels is consumed in this order:

- Step 1.** Supplies electricity for household use.
- Step 2.** Stores the excess electricity in batteries.
- Step 3.** Pushes the excess electricity onto the local power grid.

When the sun goes down, the household power supply is automatically switched to the batteries. If the power supply from the batteries is not sufficient, power is sourced from the local power grid.

3.11.2 BAT PRIORITY

In BAT PRIORITY mode, the batteries are only used as backup. When the grid fails, the household load is powered by the batteries. When the grid is working, the household load is powered by the grid, not by the batteries. The PV panels or the local power grid send electricity to the batteries, where it is stored until needed.

3.11.3 PEAK SHIFT

In PEAK SHIFT mode, you can determine the charging and discharging time of the battery and the amount of power taken from the grid yourself. You can set the time through the integrated EMS. For more information, see the [WORK MODE](#) subsection under [SYS SETTING](#).

4 Installation

With the E8KD/E10KD/E12KD/E15KD, you can install a PV energy storage system using either of two schemas:

- Install one hybrid inverter and two, four, six, or eight battery packs.
- Install a parallel system with multiple hybrid inverters of the same model, each with its own battery packs, connected in parallel. For more information, see [Installing a Parallel System](#).

Follow the steps in [Figure 4-1](#) to install a PV energy storage system with an E8KD/E10KD/E12KD/E15KD.

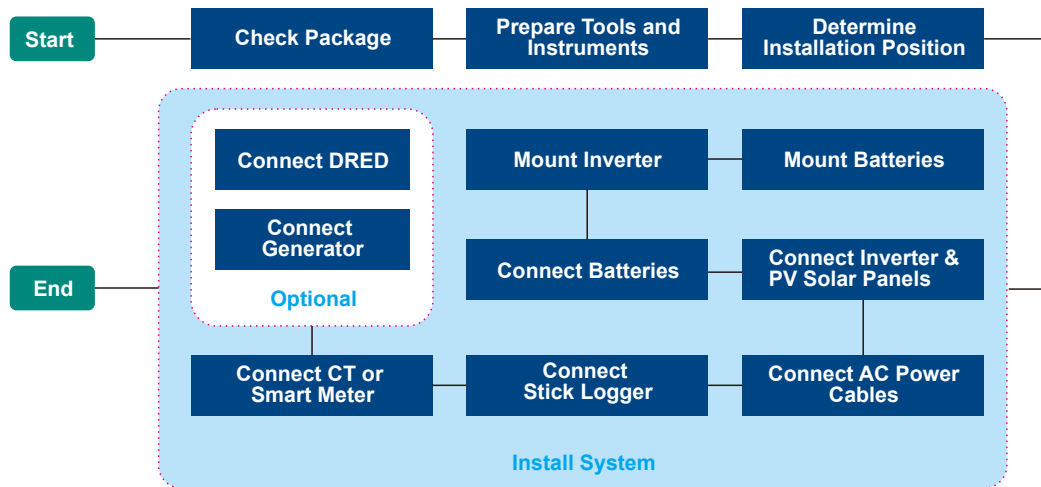

Figure 4-1 Installation Procedure

DANGER

Only trained professionals are permitted to install the system.
Three trained professionals are necessary to carry out installation.





4.1 Checking the Package

Open the package, make an inventory of its contents, and make sure that all hybrid inverter and battery pack components are present.

WARNING

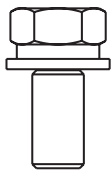
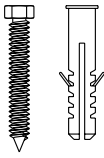
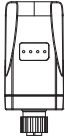
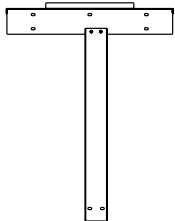

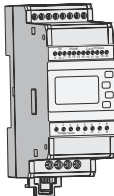
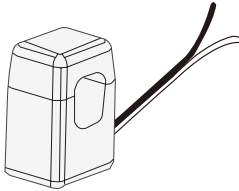
Before opening the package, make sure that the box is not damaged.

4.1.1 Hybrid Inverter Components

 <p>4 × M5*12</p>	 <p>5 × ST6.3*50 5 × D10*50</p>	 <p>1 × Stick Logger</p>
 <p>1 × Mounting Panel</p>	 <p>5 × M6 Gasket</p>	 <p>1 × User Manual</p>
 <p>1 × Smart Meter (Optional)</p>	 <p>2 × CT</p>	 <p>1 × Meter Communication Cable (5 m, Optional)</p>

4.1.2 Battery Pack Components

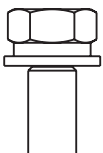
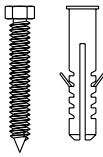
A minimum of two battery packs are necessary for an E8KD/E10KD/E12KD/E15KD energy storage system. A battery pack delivery includes the following.

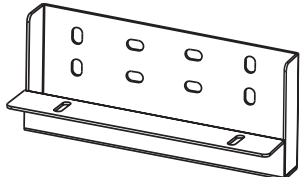
 <p>2 × M5*12</p>	 <p>4 × ST6.3*50 4 × D10*50</p>	 <p>4 × M6 Gasket</p>
 <p>1 × Mounting Kit</p>		

You can order a floor stand support for installation. For an E8KD/E10KD/E12KD/

E15KD energy storage system with four, six, or eight battery packs, battery top covers are necessary. The quantity of battery top covers and floor stand supports is determined by the number of battery packs.

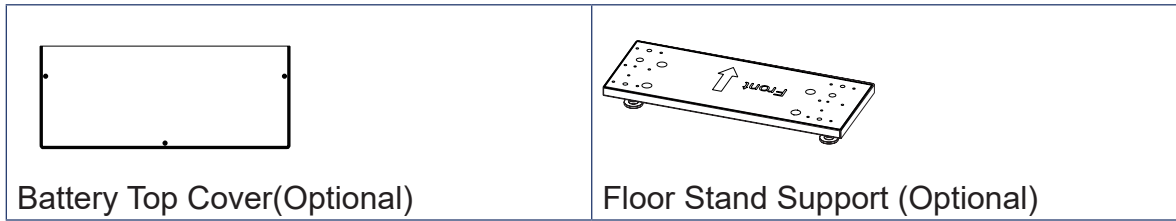

4.1.3 Cables



Here are the cables necessary for connections. The specifications and quantity of cables depends on the number of battery packs ordered.

Table 4-1 Cables for BP48100PF

Cable		Quantity			
		2 × PACK5.1	4 × PACK5.1	6 × PACK5.1	8 × PACK5.1
PE	155 mm	1	2	3	5
	475 mm	1	1	1	1
	1500 mm	0	0	1	0
	2000 mm	0	0	0	1
	2600 mm	0	1	1	0
	3100 mm	0	0	0	1
COM	450 mm	1	1	1	1
	585 mm	1	2	3	5
	2600 mm	0	1	2	2
BAT- (black)	230 mm	1	1	1	1
	480 mm	0	2	2	4
	850 mm	1	0	1	1
	1600 mm	0	1	0	0
	2600 mm	0	0	2	2

BAT+ (red)	250 mm	1	0	0	0
	480 mm	0	2	2	4
	850 mm	1	0	0	0
	1100 mm	0	1	0	0
	1600 mm	0	0	1	0
	2600 mm	0	1	3	2
	3500 mm	0	0	0	2

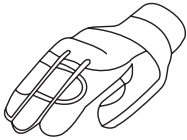
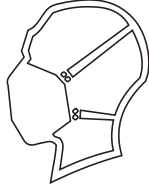
4.2 Preparing Tools and Instruments

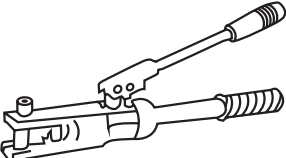
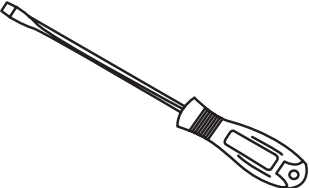
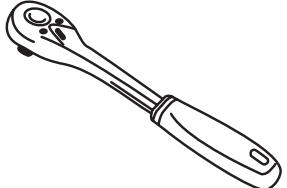
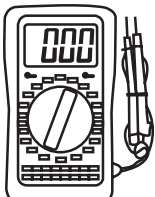
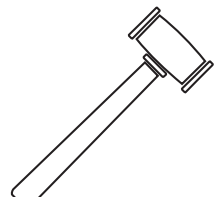
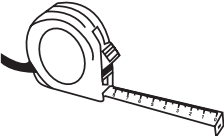
		
Protective Goggles	Protective Gloves	Protective Mask
		
Protective Shoes	Wire Clamp	Cable Crimper
		
φ10mm Power Drill	Flat-head Screwdriver	Torque Wrench
		
Cross Screwdriver	Multi-meter	Rubber Mallet
		
Leveling Instrument	Tape Measure	Marker Pen

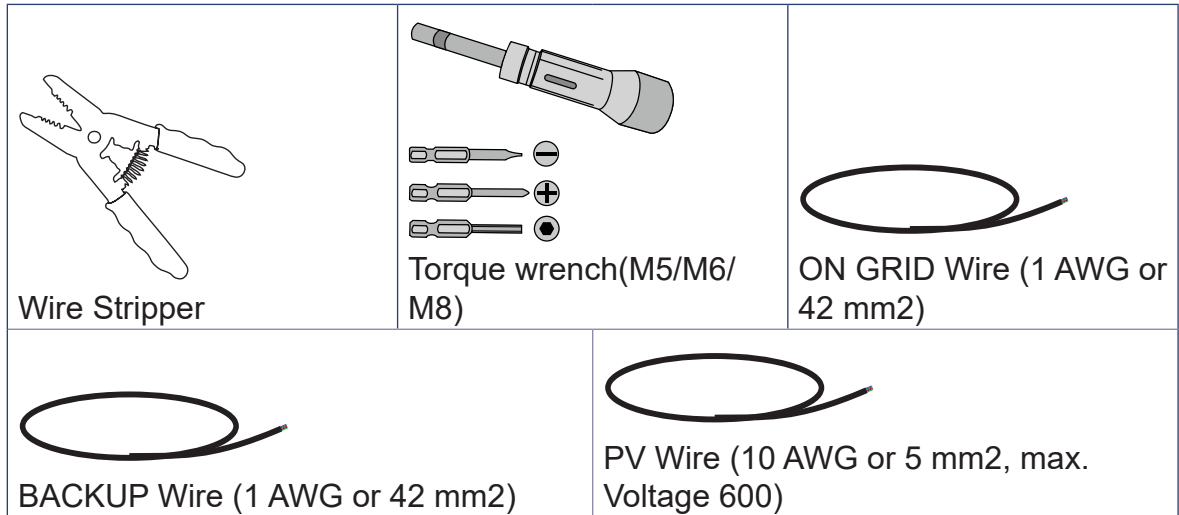

4.3 Installation Position Requirements

The E8KD/E10KD/E12KD/E15KD energy storage system can be installed indoors or outdoors, but the position for installation must meet these requirements:

- Sufficient space for personnel to install and maintain the equipment and to operate the LCD screen on the hybrid inverter and the control panels of the battery packs.
- Ambient temperature: For the inverter and battery pack. See [Specifications](#).
- Relative humidity: 0–95% (No condensation).
- Level floor, but not sloped.
- Sheltered from direct sunlight or severe weather.
- Well ventilated
- NOT near flammable or explosive materials.
- NOT exposed to salt hazards.
- NOT subject to strong vibration or electromagnetic fields.
- NOT a habitable room, in accordance with local regulations.
- NOT accessible to children.

4.3.1 Restrictions

DO NOT install the system in these locations:

- Habitable rooms, in accordance with local regulations.
- A ceiling or wall with a cavity
- On a roof
- Entrance or exit
- Underneath staircases or passageways
- Areas where relative humidity and condensation exceed 95%
- Places exposed to salty air
- Earthquake zones, unless additional safety measures have been taken
- Places at more than 2,000 meters above sea level

- Places in direct sunlight or places where the ambient temperature varies a lot
- Places with flammable materials and gases
- Places where explosions may occur.
- • Locations where the installation of panels is restricted by local regulations.
- Within 600 mm of any heat source, for example, hot water unit, gas heater, air conditioning unit, or any other equipment.
- Within 600 mm of any outlet.
- Within 600 mm of any window or vent.
- Within 600 mm of the side of any other installation.
- • Hazardous areas with insufficient distance from gas cylinders or gas relief valves as defined in local regulations.

When the E8KD/E10KD/E12KD/E15KD is installed indoors, make sure that the building structure, room furniture, and appliances do not interfere with the operation and maintenance of the system.

If the E8KD/E10KD/E12KD/E15KD is installed in a corridor, aisle, lobby, or similar area that leads to an emergency exit, at least one meter of space must be allowed for safe egress.

To prevent fire, the wall or structural surface on which the E8KD/E10KD/E12KD/E15KD is mounted must be made of non-combustible material. If the wall or structural surface is not made of non-combustible material, a layer of non-combustible material can be placed between the equipment and the surface.

4.3.2 Clearance Requirements

If the E8KD/E10KD/E12KD/E15KD is mounted on a wall or on a surface that is 300 mm from a wall or structure that separates the equipment from habitable rooms, the distance between the equipment and other structures or objects must be increased. The minimum required clearance is as follows:

- 600 mm to the sides of the equipment
- 500 mm above the equipment
- 600 mm in front of the equipment

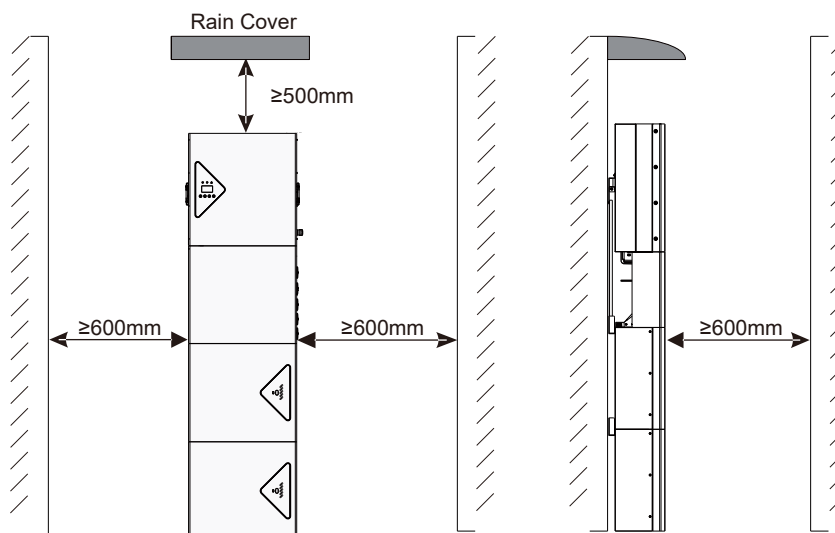

Figure 4-2 Peripheral Clearance Requirements for Installation

NOTICE

- For outdoor installations, a shelter above the equipment is necessary.
- When installing the E8KD/E10KD/E12KD/E15KD, make sure that the distance between the highest point of the equipment and the ground or the mounting platform does not exceed 2.2 meters.

If the distance between the E8KD/E10KD/E12KD/E15KD and the object above it, for example, a ceiling, is less than 500 mm, the surface of the object must be paved with non-combustible material in the form of a circle with a radius of 600 mm around the center of the equipment.



The minimum distance between the E8KD/E10KD/E12KD/E15KD and the object above it must be more than 200 mm.

4.4 Installing the System

Follow the steps in this section to install an E8KD/E10KD/E12KD/E15KD energy storage system with one hybrid inverter.

4.4.1 Mounting Battery Packs

Move the battery pack from the packaging box and mount it on the wall.

NOTES

- The battery pack should be moved by three persons. One battery pack weighs more than 56 kg.
- Wear protective goggles and mask to prevent the dust created during drilling from entering the respiratory tract and eyes.
- Move the battery pack horizontally.

PROCEDURE

Step 1. If you ordered a floor stand support, use a flat screwdriver and a wrench to fasten the footpads to the floor stand support. Put the floor stand support in the orientation marked “Front” on the support. Use a leveling instrument to make sure that the floor stand support is level.

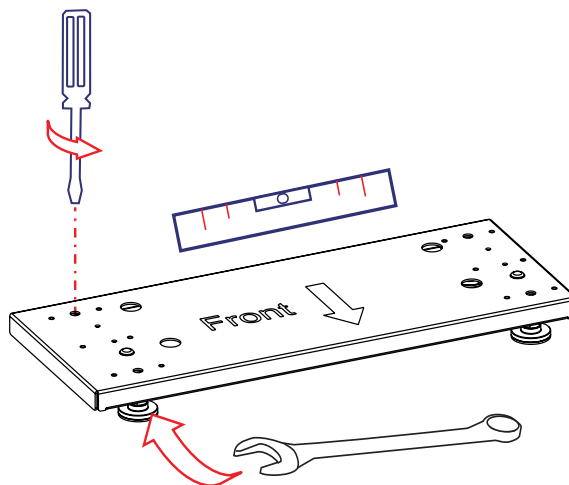

Step 2. Align the first battery pack with the wall. Use a leveling instrument to make sure it is level.

If a floor stand support is used, align it with the wall, make sure it is 3~4 cm away from the wall, and then put the first battery pack on it. Use the stamped bumps on the floor stand support to align the first battery pack.

WARNING

Make sure that the wall surface for mounting the battery pack is stable.

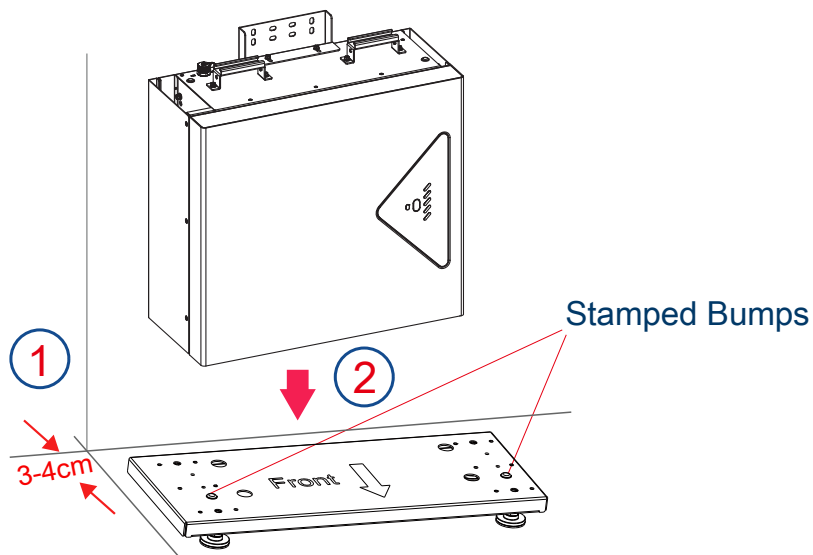

Step 3. Put the mounting kit on the battery, align it with the wall, identify the four locations where the holes will be drilled and mark them with a marker.

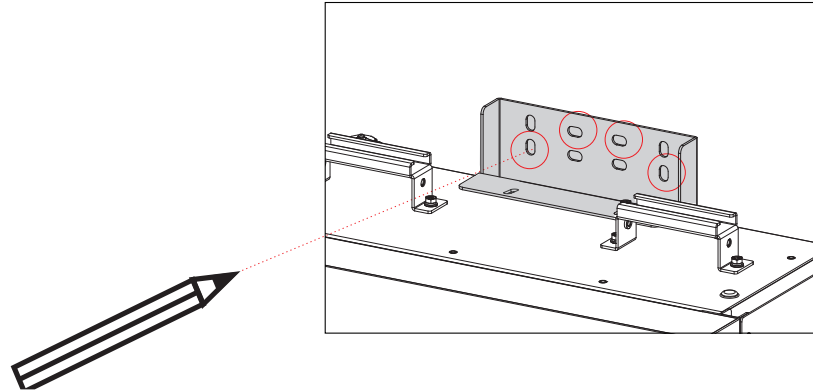

⚠ DANGER

To avoid potential dangers, make sure that no water pipes are inside the wall on which the battery pack is to be mounted.

- Step 4.** Use a power drill to drill the holes. The diameter of the hole is approximately 10 mm, and the depth is approximately 70 mm.
- Step 5.** Use a rubber mallet to drive D10*50 into the holes, and then use the gaskets and the ST6.3*50 expansion screws to fix the mounting kit to the wall.

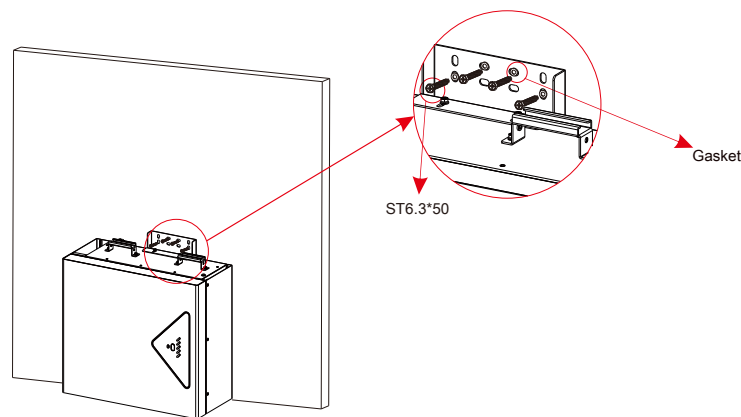

- Step 6.** Use the M5*12 screws to secure the mounting kit to the first battery pack.

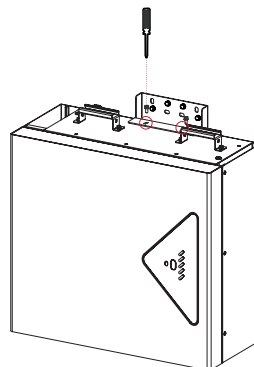

- Step 7.** Align the two battery packs, using the stamped bumps on the top of the first battery pack.



Before you put a battery pack on top of another one, make sure that the max inclination of the wall is 1.5%.

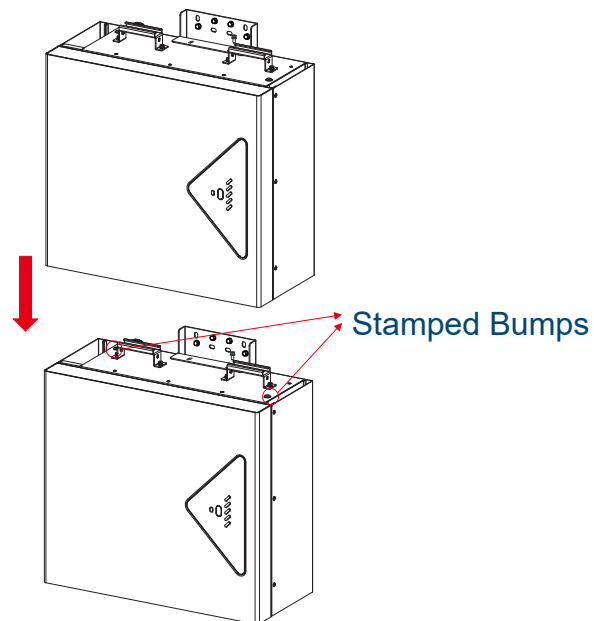

- Step 8.** Stack the mounting panel in front of the mounting kit, identify the four locations where the holes will be drilled, and then mark them with a marker.

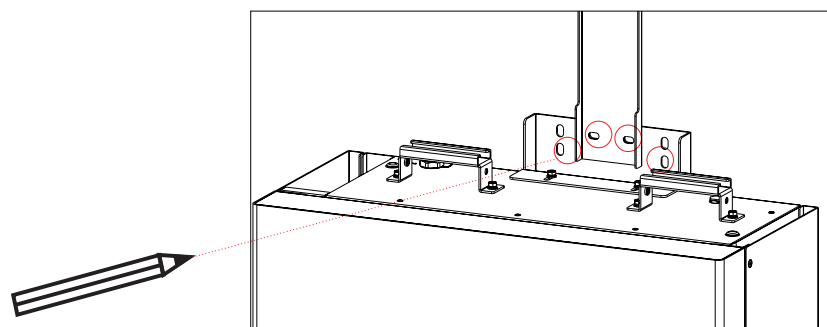

- Step 9.** Identify the locations of the five holes for fixing the mounting panel to the wall and mark them with a marker.

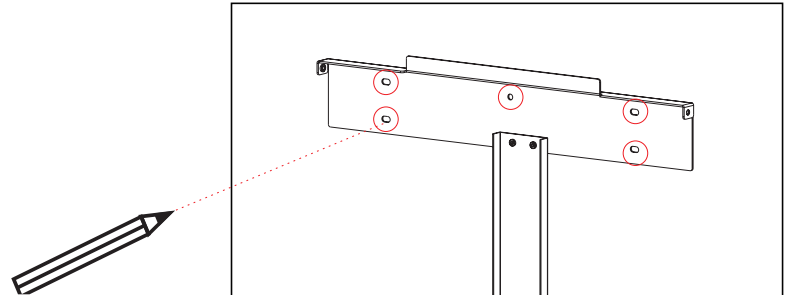

NOTICE
Make sure that the mounting panel and the battery pack are perpendicular to each other.

- Step 10.** Use a power drill to drill the holes. The diameter of the holes is approximately 10 mm, and the depth is approximately 70 mm.
- Step 11.** Use the rubber mallet to drive D10*50 into the holes, use the gaskets and the ST6.3*50 expansion screws to fix the mounting kit together with the mounting panel to the wall, and then use the M5*12 screws to secure the mounting kit to the second battery pack.
- Step 12.** Use the rubber mallet to drive D10*50 into the holes, and use the gaskets and the ST6.3*50 expansion screws to fix the mounting panel to the wall.

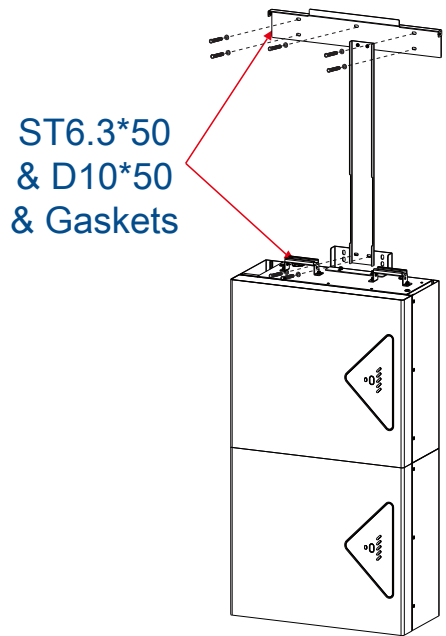

- Step 13.** If you want to mount four, six, or eight battery packs, mount and stack the battery packs as shown in these figures.

CAUTION
The distance between two stacks of battery packs must be 300–400 mm.

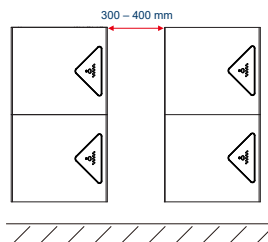

Figure 4-3 Mounting Four Battery Packs

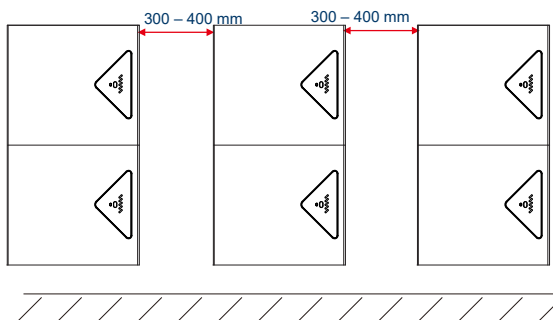

Figure 4-4 Mounting Six Battery Packs

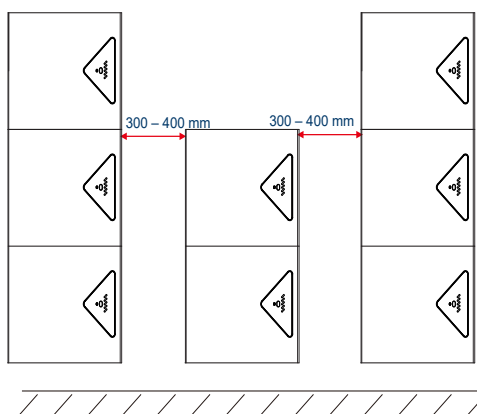

Figure 4-5 Mounting Eight Battery Packs

4.4.2 Mounting the Inverter

NOTES

The inverter should be moved by four persons. One inverter weighs approximately 73 kg.

Wear protective goggles and a mask to prevent the dust created during drilling from entering the respiratory tract or eyes.

PROCEDURE

Step 1. Hook up the inverter to the mounting panel and use the M5*12 screws(size:20Kgf.cm) to secure the inverter to the top battery pack and the mounting panel.

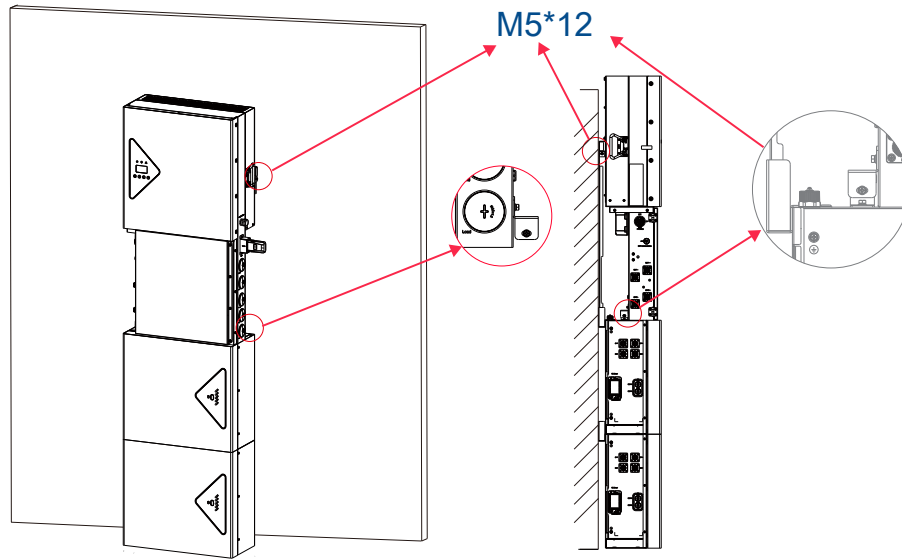

Step 2. If four, six, or eight battery packs were mounted, follow Step 1 to mount the inverter on the stack of battery packs as shown in these figures.

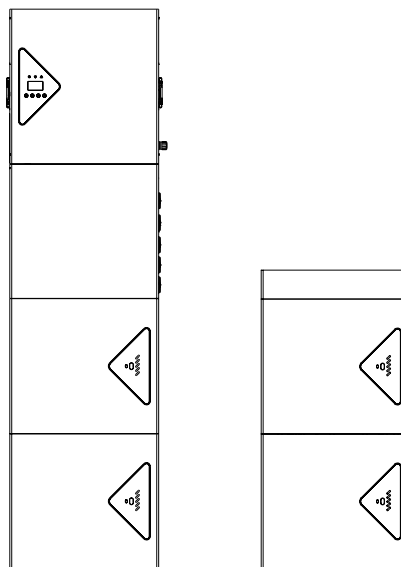

Figure 4-6 Mount an Inverter for Four Battery Packs

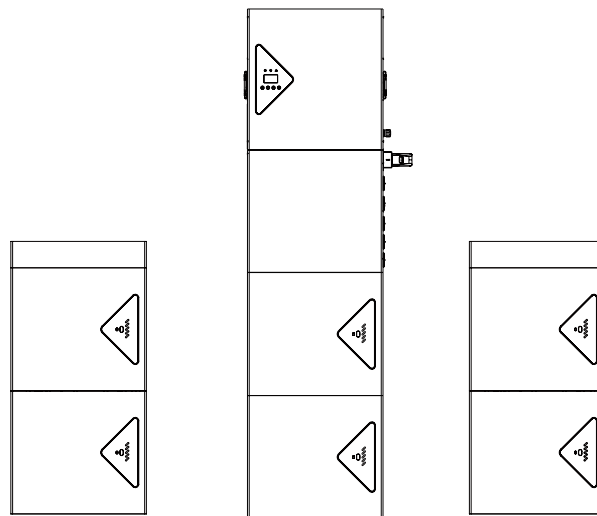

Figure 4-7 Mount an Inverter for Six Battery Packs

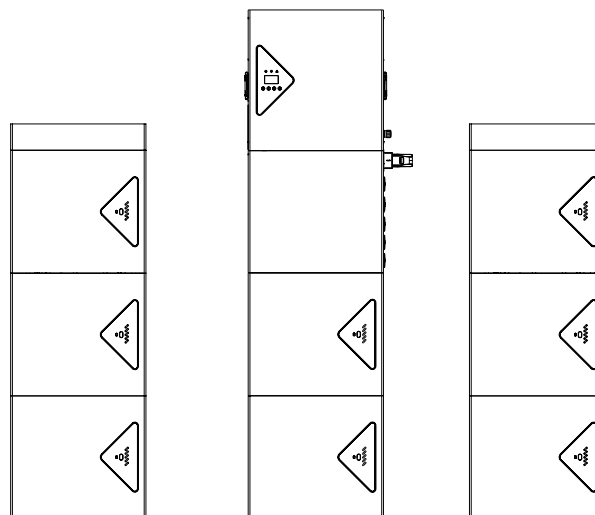

Figure 4-8 Mount an Inverter for Eight Battery Packs

4.4.3 Connecting Battery Packs

NOTES

- Before connection, make sure that the voltages of the batteries are correct.
- Make sure that both the Battery Switch inside the cable box and the DC Switch inside the side cover of a battery pack are in the OFF state. For more information, see [Breaker and Terminal](#) of the inverter.

PROCEDURE

- Step 1.** On the battery packs, remove the screws on the side covers and open the covers.

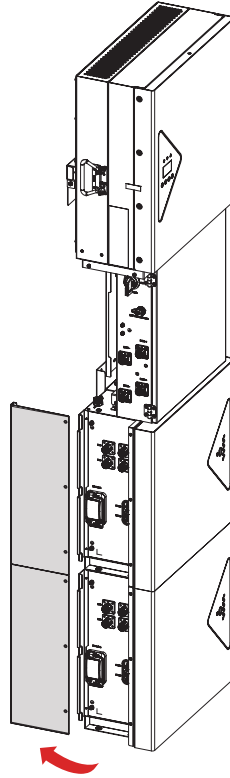

- Step 2.** Remove the screws from the PE port inside the cable box and the PE1 port on the side of the top battery pack. Use the 475 mm PE cable (G-475) to connect the ports and then replace the screws.

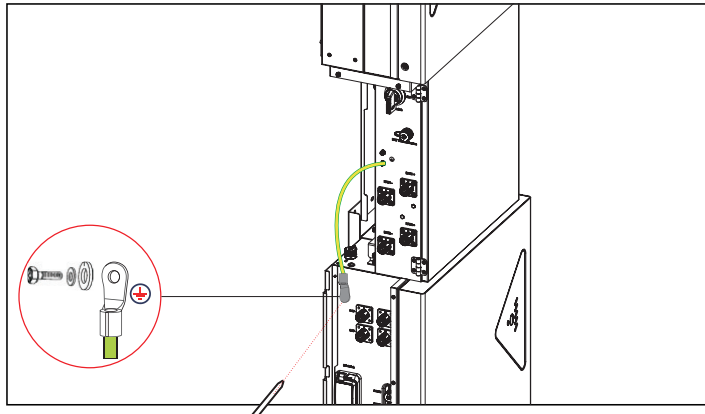

- Step 3.** Use the BAT cables (DR-250 and DB-230) to connect the BAT+ and BAT- ports inside the cable box and on the side of the second battery. Use the 850 mm BAT cables (DR-850 and DB-850) to connect the BAT+ and BAT- ports inside the cable box and on the side of the first battery.

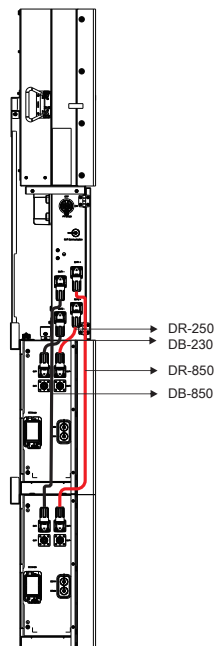

CAUTION

All battery cables need to be pressed in place when connected until a "click" is heard.

- Step 4.** Follow this diagram to make the connections:
- Use the 450 mm COM cable (C-450) to connect the BAT port inside the cable box and the INV port on the battery pack.
 - Use the 585 mm COM cable (C-585) to connect the lower COMM port of the second battery pack and the upper COMM port of the first battery pack.
 - Remove the screws from the PE ports of the battery packs, use a 155 mm PE cable (G-155) to connect the PE ports between the two battery packs, and then replace the screws.

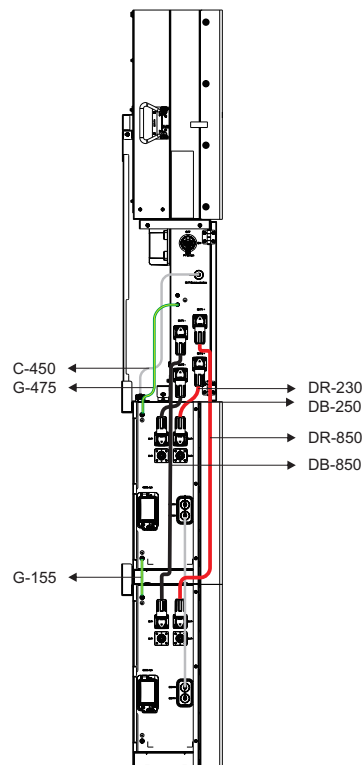

Step 5. If you mounted four, six, or eight battery packs, connect them as shown in these diagrams.

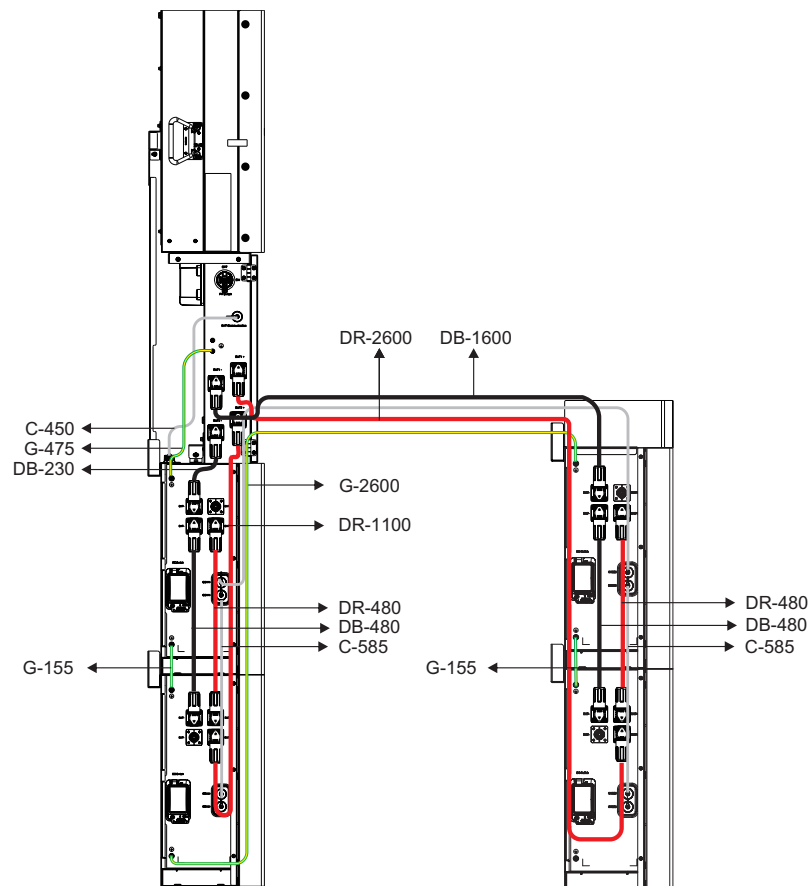

Figure 4-9 Connect Four BP48100PF

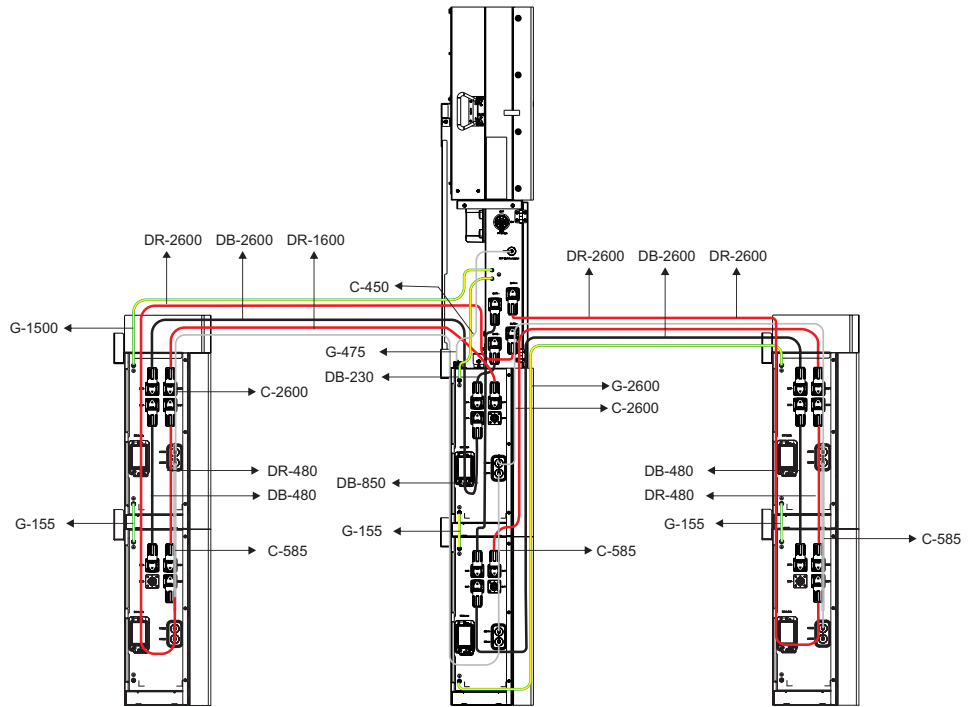

Figure 4-10 Connect Six BP48100PF

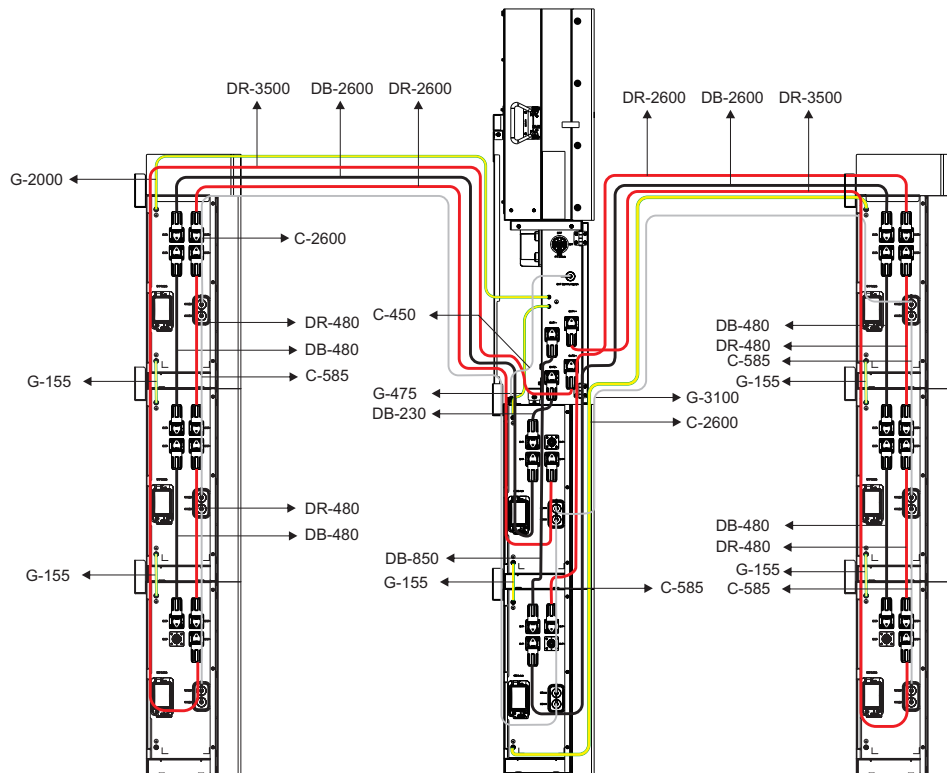

Figure 4-11 Connect Eight BP48100PF

Step 6. Close the side covers of all the battery packs and replace the screws.

Step 7. Put the top covers on the battery packs and tighten the screws as shown in these figures.

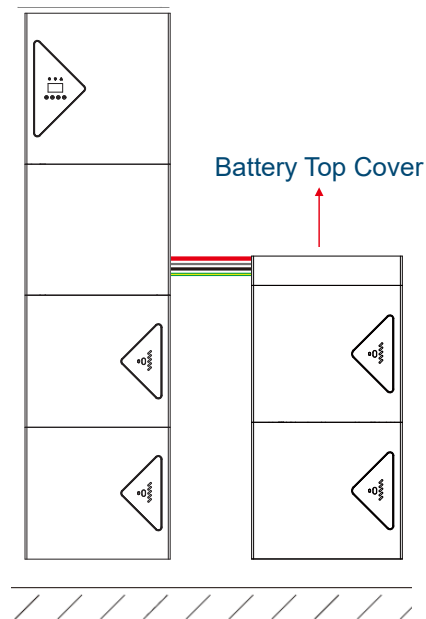

Figure 4-12 A System with Four BP48100PF (With Top Covers)

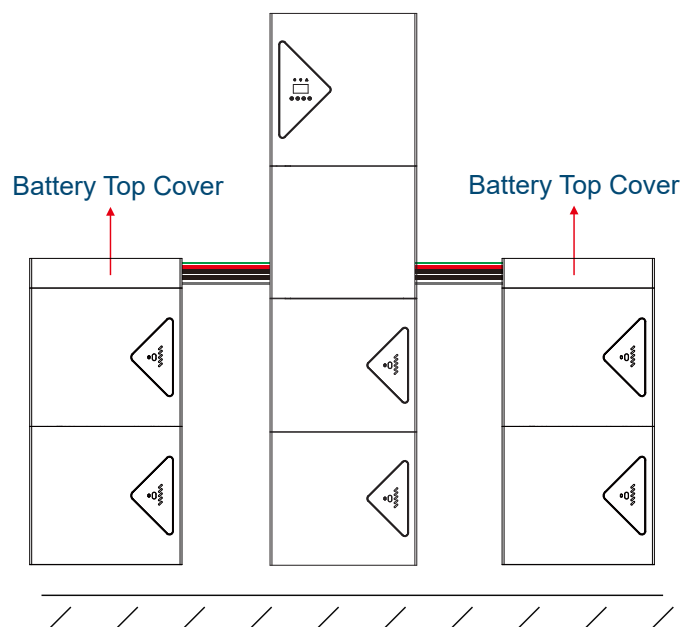

Figure 4-13 A System with Six BP48100PF (With Top Covers)

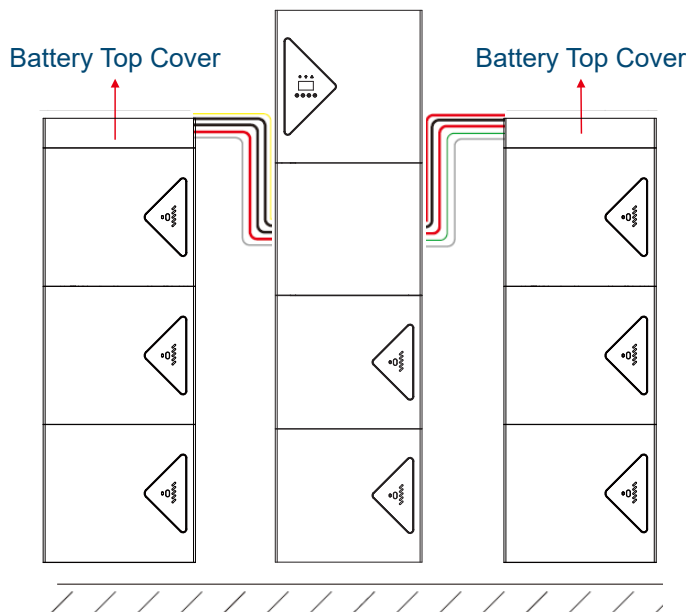

Figure 4-14 A System with Eight BP48100PF (With Top Covers)

4.4.4 Connecting the Inverter and PV Solar Panels

NOTES

- 10 AWG or 5 mm² PV wires are recommended for connection.
- Distinguish the PV polarities and DO NOT reverse the connection.
- Make sure that the input voltage of the PV is within the acceptable input voltage range of the inverter, not higher than 500 V.

⚠ DANGER

Make sure that the PV Switch outside the cable box and the switch on the PV solar panel are in the OFF position.

PROCEDURE

- Step 1.** Use a wire stripper to remove an approximately 8 mm length of insulation layer of the PV wire.
- Step 2.** Thread the stripped part of the PV wire into the terminal and press it tightly with crimping pliers.

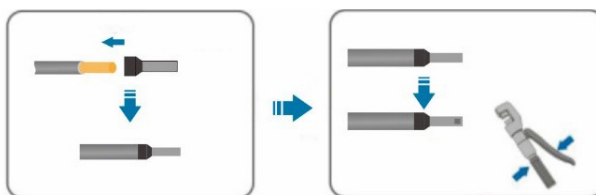

- Step 3.** Use a multi-meter to measure the voltage of the PV wire. Make sure that the voltage is lower than 500 V.

4 Installation

- Step 4.** Follow steps 1 through 3 to prepare other three PV wires for negative and positive connections.
- Step 5.** Before connecting cables, open the distribution box cover and remove the insulation cover.
- Step 6.** Plug the PV wires into the PV1+, PV1-, PV2+, PV2-, PV3+ and PV3- connection terminal on the EMI Board and snap them.



E8KD/E10KD Only PV1 and PV2, E12KD/E15KD there are PV1, PV2 and PV3.

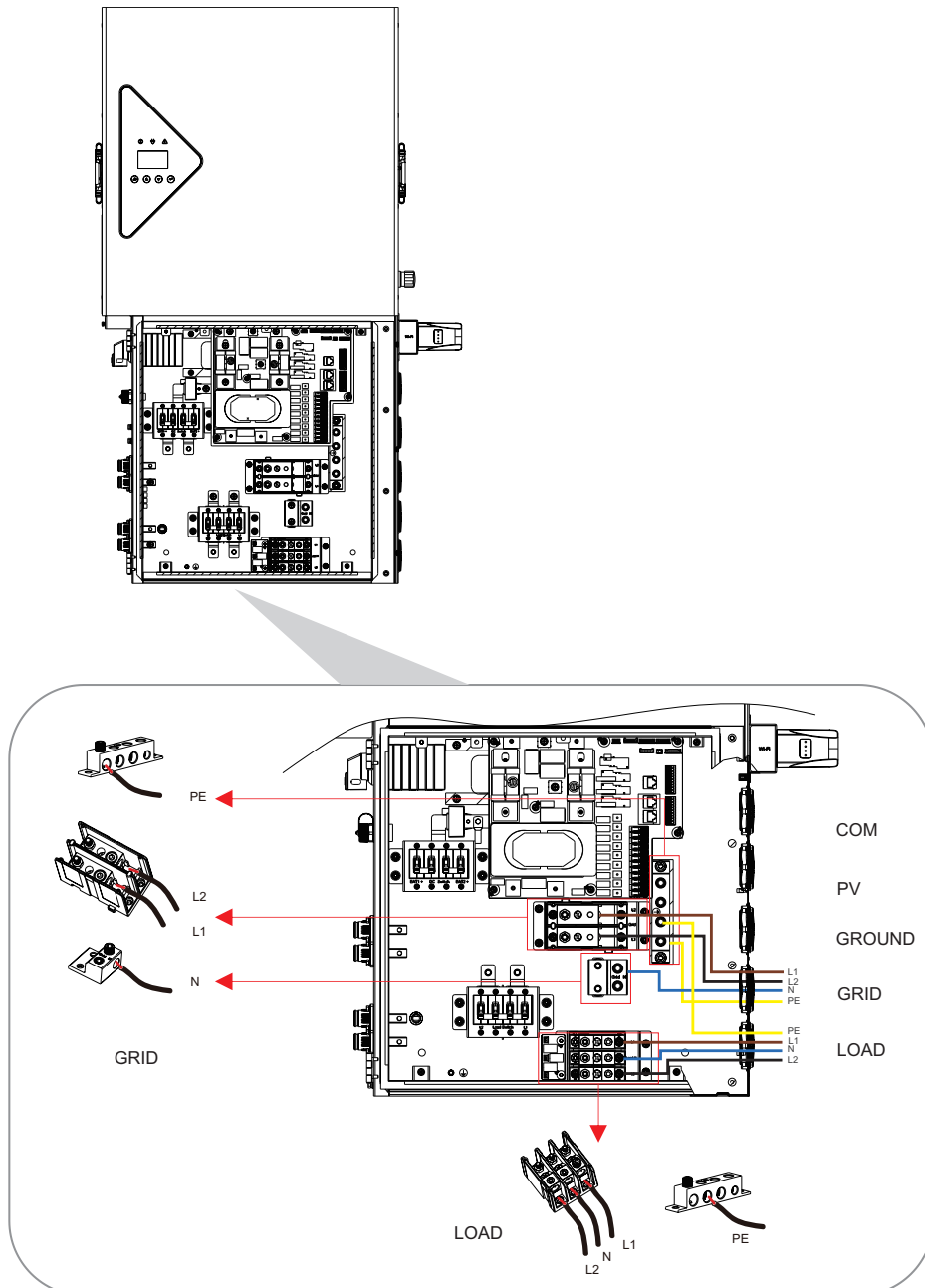

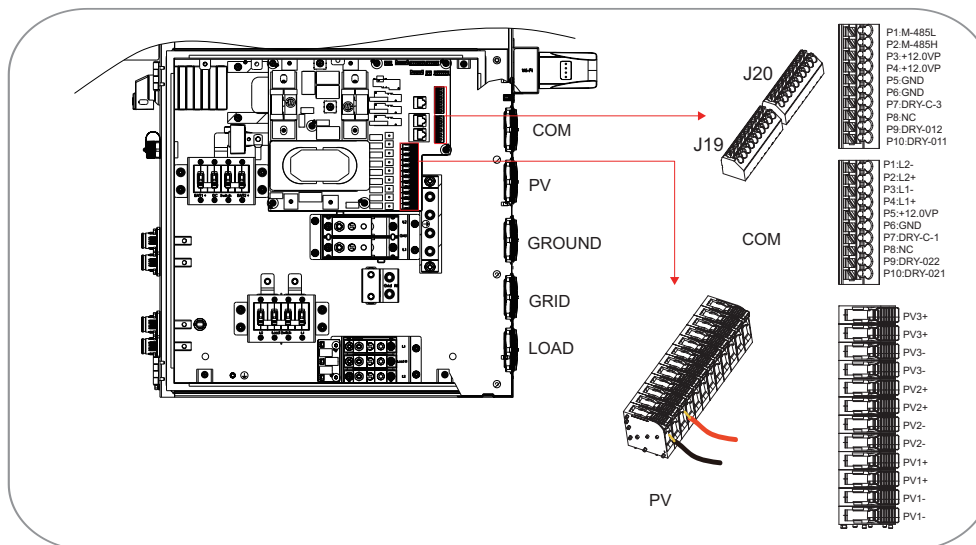

Figure 4-15 The terminal box of the inverter

4.4.5 Connecting to Grid and Loads

Two four-wire AC cables are necessary for ON GRID connection and BACK UP connection of the inverter.

NOTICE

- Recommended cables: a 1 AWG or 42-mm² cable for BACK UP and ON GRID connection.
- Make sure that the resistance of the wires is lower than 1 Ω .
- Make sure that the grounding resistance, measured between the inverter case and the earth terminal of the distribution box, is less than 10 Ω .
- Grid N and Load N lines connection mode of the inverter, refer to the Wiring diagram in Section 3.9.

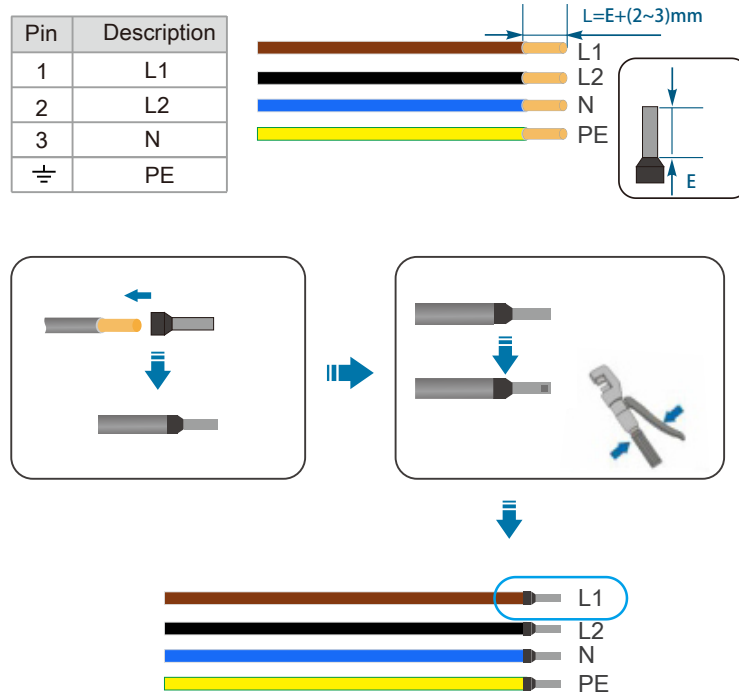

Figure 4-16 Four-wire AC Cable

<p>L1: Grid L1 line to be connected to L1 of the Grid connector to serve as the L1 phase wire. Load L1 line To be connected to L1 of the load connector to serve as the L1 phase wire.</p>	<p>L2: Grid S line to be connected to L2 of the Grid connector to serve as the L2 phase wire. Load L2 line To be connected to L2 of the load connector to serve as the S phase wire.</p>
<p>N: Grid N line to be connected to N of the Grid N connector to serve as the N phase wire. Load N line to be connected to N of the Load N connector to serve as the N phase wire.</p>	<p>PE: To be connected to PE connector to serve as the earth wire.</p>

⚠ DANGER

Before connection, make sure that the DC switch and the LOAD switch inside the cable box are in the OFF state.

⚠ CAUTION

When connecting the wires to the connector, make sure that the phase wires, the neutral wire, and the earth wire are connected correctly.

⚠ CAUTION

Appliances such as air conditioners require sufficient time to equalize refrigerant gases within the circuit, so it takes at least two or three minutes to restart. If power supply is short-circuited and restored within a short period, it can cause damage to these appliances connected to the power supply. Before installing such appliances, make sure that the air conditioner has a time delay function to prevent such damage. In the absence of a time delay function, the inverter triggers an overload fault and cuts off the output to protect your appliances, but internal damage to appliances can sometimes still occur.



The type A or B RCD should be installed on the BACK UP port of the system according to local regulations.

An AC circuit breaker of these specifications is recommended:

- For GRID and BACK UP connection: 200 A/400 VAC 6 KA

4.4.6 Connecting a Stick Logger

Before installing the collector, remove the collector protective gear.

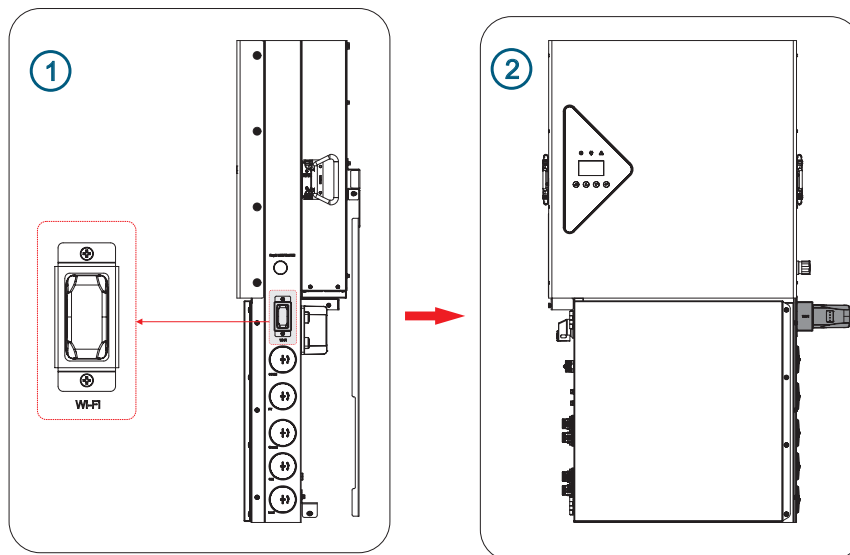

NOTES

For more information, see *Stick Logger Quick Guide*.

WARNING

DO NOT hold the logger body to rotate while installing or removing the logger.



PROCEDURE

Step 1. Plug the stick logger into the COM port inside the cable box.

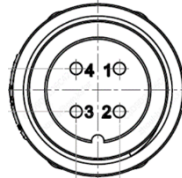

Figure 4-17 Pins of the COM Port

Pin 1: +5V
Pin 2: GND
Pin 3: RS485-A
Pin 4: RS485-B

4.4.7 Connecting External CTs

You must connect external CTs or a smart grid meter between the inverter and the power grid.

If you want to connect a smart meter, see [Connecting a Smart Meter](#).

If you want to connect external CTs, two CTs are necessary. The CT is connected to the J19 of the EMI board, as shown in Figure 4-18.

L1 phase CT positive pole (White) connected to the L1+ of J19.

L1 phase CT negative pole (Black) connected to the L1- of J19.

L2 phase CT positive pole (White) connected to the L2+ of J19.

L2 phase CT negative pole (Black) connected to the L2- of J19.

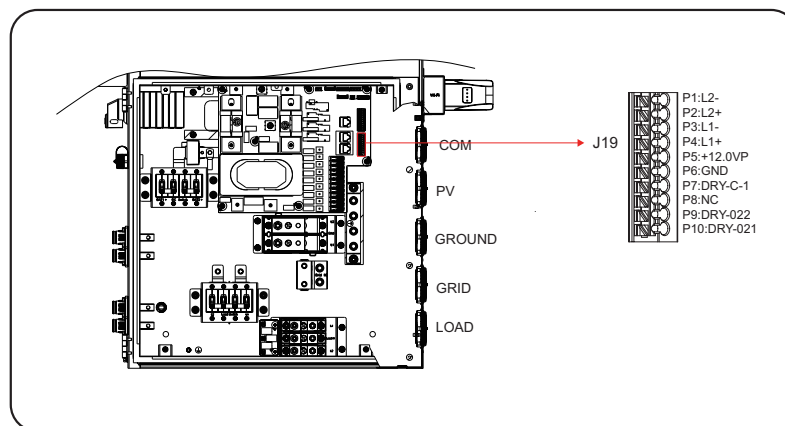

Figure 4-18 Pins of CT

NOTES

Only the CTs provided by the manufacturer can be connected to the system.

You must mark the CTs as L1 and L2.

The external CTs must be mounted near the power grid side. If the CT test passes but the inverter output power is not acceptable, for example, power cannot be controlled or output power is always 0 W, check the position where the CTs are mounted.

You can run a CT self-check. For more information, see [CT SELF CHK](#).

PROCEDURE

Step 1. Open the external CT wiring port, the arrow points to the direction of the power grid, put the wire into the external CT card slot, and buckle the buckle. Follow this figure for wiring.

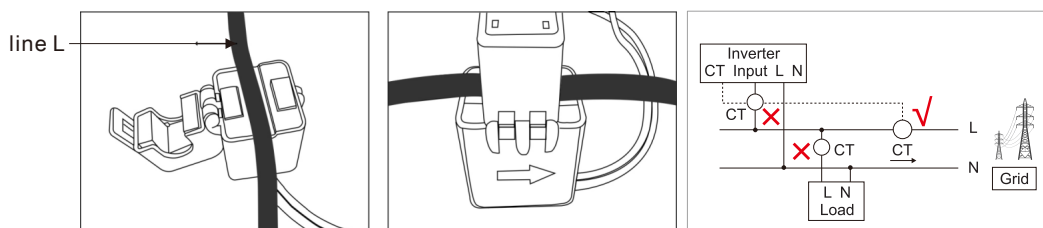
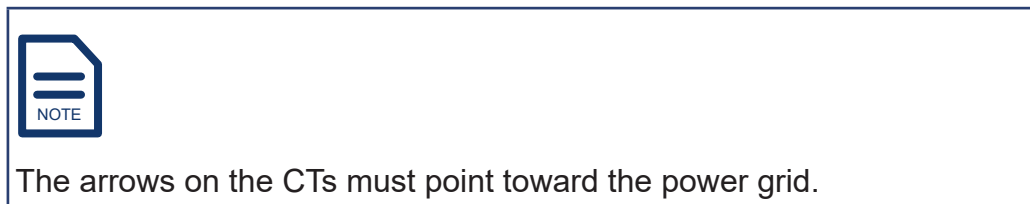

Step 2. If no further electrical connections are necessary, close the cover of the cable box, tighten the screws, and then go to Commissioning.

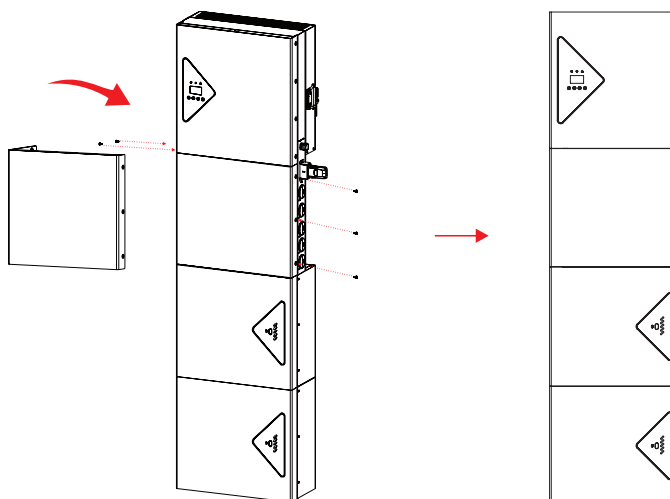

4.4.8 Connecting a Smart Meter

You must connect external CTs or a smart grid meter between the inverter and the power grid.

If you want to connect external CTs, see [Connecting External CTs](#).

If you want to connect a smart meter, note that only one meter is necessary for each inverter. The meter must be mounted and connected at the grid transition point (feed-in point) so that it can measure the grid reference and feed-in power.

To connect a smart meter, a CT&Meter connector is necessary and it must be connected to the J20 of the EMI board inside the cable box, as shown in Figure 4 19. Wiring according to the meter instructions.

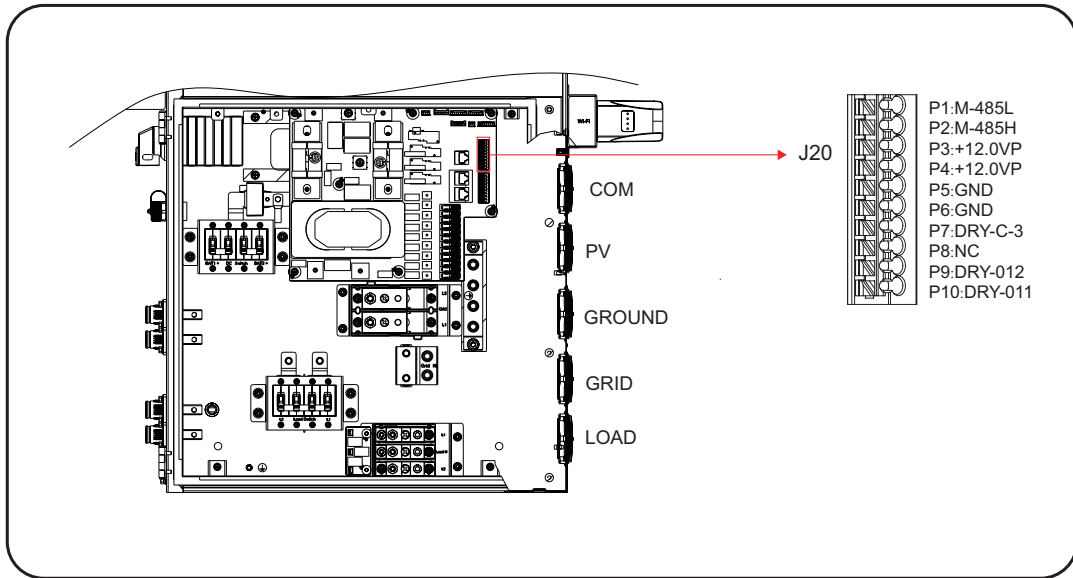

Figure 4-19 Pins of Meter

NOTES

NOTICE

Currently, only these brands of smart meters are supported: Easton, Acrel, Rayleigh, YaDa, and CHINT. You can set the smart meter brand in the integrated EMS. For more information, see the [CT OR METER](#) subsection under [SYS SETTING](#).

The CHINT DTSU666 250A/50mA is recommended. The smart meter with CTs is already configured. **DO NOT** change any settings on the smart meter.

PROCEDURE

- Step 3.** Prepare the communication wires, power cable, and tools for the meter connection.
- Step 4.** Follow the meter installation manual to install the meter.



The arrow on the CT must point toward the power grid.
Two CTs must be used for one smart meter and must be connected to the same phase with the smart meter power cable.

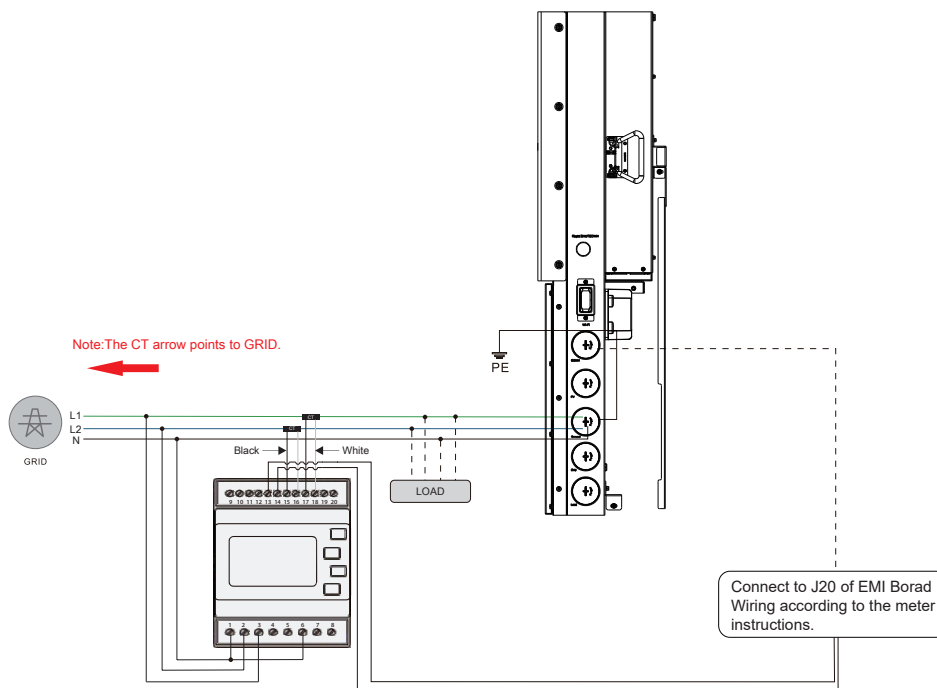
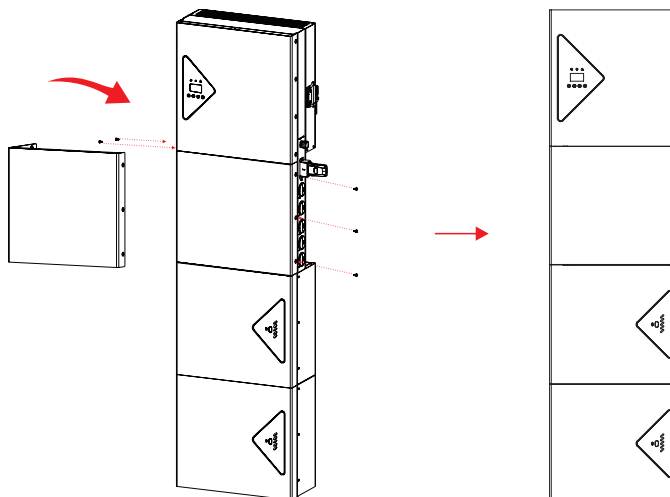

Figure 4-20 Wiring of Smart Meter Connection (Example, DTSU666)

- Step 5.** On the inverter side, follow steps 1 through 3 of Connecting External CTs to process the communication wire, plug the connector into the METER+DRY port inside the cable box, and then tighten it.
- Step 6.** If no further electrical connections are necessary, close the cover of the cable box, tighten the screws, and then go to Commissioning.



4.4.9 (Optional) Connecting a Generator

If you are using a generator, you can connect the generator to the E8KD/E10KD/E12KD/E15KD energy storage system.

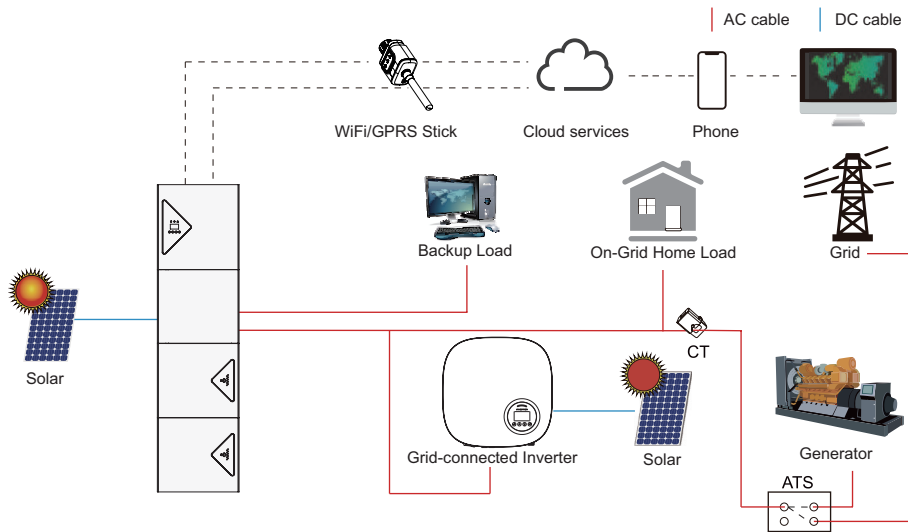

Figure 4-21 Connect a Generator

4.5 Installing a Parallel System

The E8KD/E10KD/E12KD/E15KD supports installation of a parallel system with more than one inverter. A maximum of four inverters can be connected in parallel. For more information, see [Parallel System](#).

4.5.1 Wiring of a Parallel System

Follow these figures for wiring of a parallel system with two, three, or four inverters.

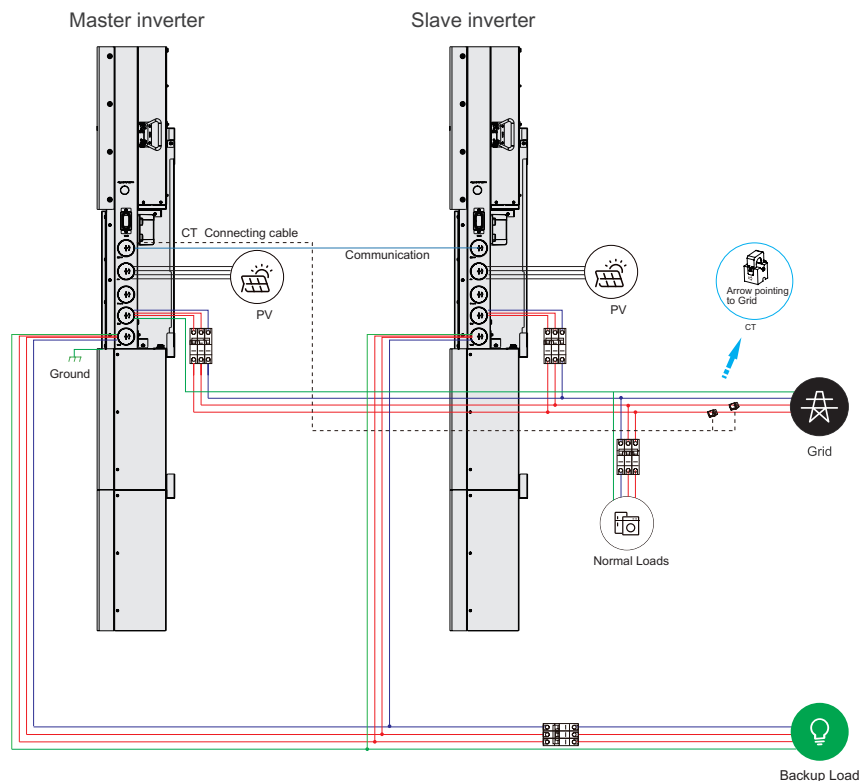

Figure 4-22 Wiring of a Parallel System with Two Inverters

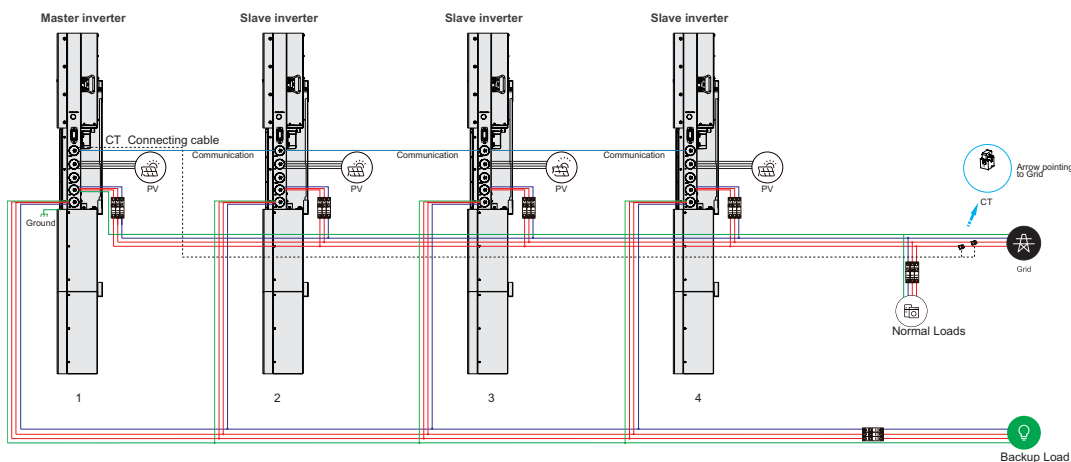



Figure 4-23 Wiring of a Parallel System with Four Inverters

4.5.2 Installation Prerequisites

- Make sure that all the inverters are mounted and connected to the PV solar panels. For more information, see [Mounting the Inverter and Connecting the Inverter and PV Solar Panels](#).
- Make sure that all the battery packs are mounted and connected. For more information, see [Mounting Battery Packs and Connecting Battery Packs](#).
- Make sure that the grid and load connections to each inverter are correct. For more information, see [Connecting to Grid and Loads](#).
- Decide which inverter serve as the primary inverter.



Make sure that only the primary inverter connects a set of CTs or an electricity meter. DO NOT connect CTs or an electricity meter to the subordinate inverters. For more information, see [Connecting External CTs](#) or [Connecting a Smart Meter](#).

- Prepare an 8-core Category-6 cable. The recommended length is no more than 10 m.

Table 4-2 QTY of Cables for a Parallel System

Inverter	Cable
2	1
3	2
4	3

Table 4-3 Pin Description of the Parallel Ports of Parallel Connector

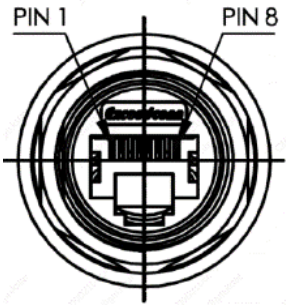
	Pin	Description
	1	CAN_H
	2	CAN_L
	3	INV_STATUS_BC
	4	BPSIDE_HOLD_BC
	5	MASTER_SYN_BC
	6, 7, 8	GND

4.5.3 Installation Procedure

- Step 1.** Plug one end of the cable into the connector CN14 or CN15 on EMI board, and the other end of cable into the connector CN14 or CN15 on EMI board of other inverter.
- Step 2.** If three or four inverters are connected, repeat Step 1 on the other inverter.

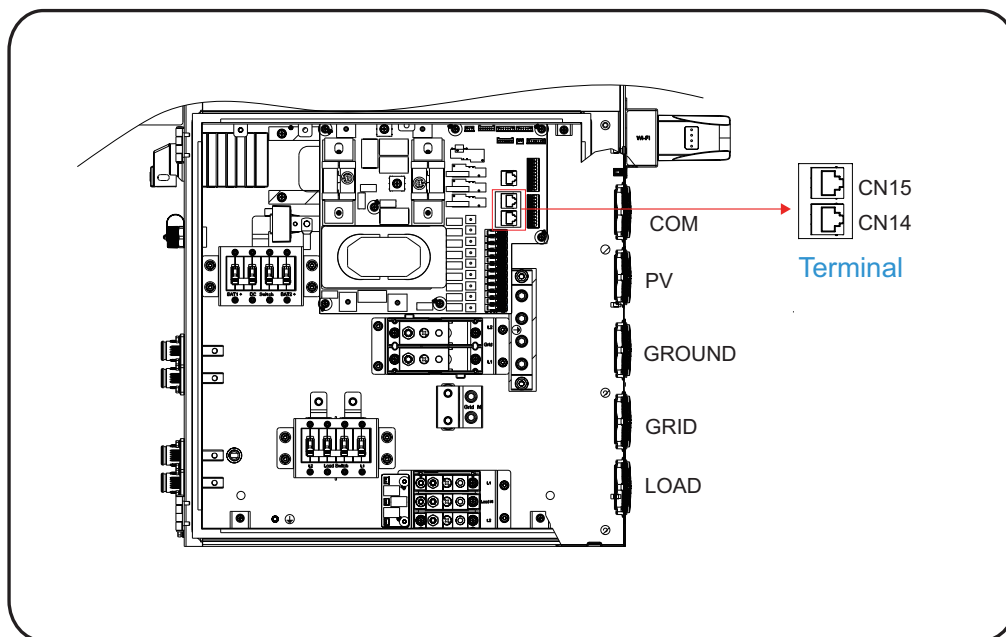

Figure 4-24 Parallel communication port

Step 3. Check the connections.

CAUTION

To protect the inverter from burning, the R, S and N connection for the ON-GRID connection and the BACK UP connection must be completed correct.

- Step 4.** Power on all the inverters of the parallel system. For more information, see [Powering On](#).
- Step 5.** On the LCD screen of the primary inverter, enable the parallel feature and set the address to 1. For more information, see the [PARALLEL](#) subsection under [SYS SETTING](#).
- Step 6.** On the LCD screens of the other inverters, enable the parallel feature and set the address to 2, 3, or 4. For more information, see the [PARALLEL](#) subsection under [SYS SETTING](#).



If the address setting is incorrect, an F22 error occurs. For more information about the error, see [Error Codes of the System](#).

- Step 7.** If external CTs are connected to the primary inverter, disconnect all the subordinate inverters, and run a CT SELF-CHECK. For more information, see [CT SELF CHK](#).

5 Commissioning

Follow the steps in [Figure 5-1](#) to commission the system.

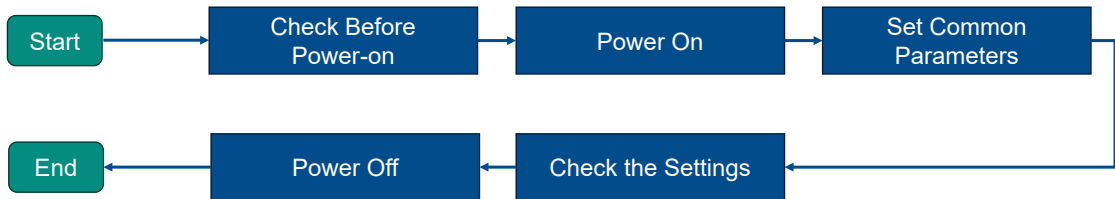

Figure 5-1 Commissioning Procedure

5.1 Checking Before Power-on

Before powering on the system, thoroughly check the installation.

- Step 1.** Make sure that the E8KD/E10KD/E12KD/E15KD is firmly fastened to the mounting panel on the wall.
- Step 2.** Check the electrical connection inside the cable box. Make sure that:
 - PV+ and PV- cables are firmly connected and the polarity and voltage are correct.
 - The GRID and Back Up cables are connected firmly and correctly.
- Step 3.** Open the side covers of the battery packs and make sure the COMM connections are correct.

5.2 Powering On

NOTICE

If the photovoltaic plate is equipped with AP Smart rapid shutdown device, You must first turn on the battery or the grid, After the inverter display lights up, PV will have electricity.

- Step 1.** Turn on the external PV switch.
- Step 2.** Turn on the breaker between the GRID port and the grid.
- Step 3.** Turn on the battery pack. For more information, see [Turning on a Battery Pack](#).
- Step 4.** Open the side cover of the battery pack and turn on the DC Switch. If more than one battery pack is installed, repeat steps 3 and 4.
- Step 5.** In the cable box, turn on the Battery Switch.
- Step 6.** If backup loads are applied, turn on the LOAD Switch in the cable box.



The LOAD Switch is necessary only when a backup load is connected.

- Step 7.** Close the side covers of the battery packs and the cover of the cable box.

5.3 Setting Common Parameters for the System



In a parallel system, all settings must be the same for all inverters except for the addresses of the inverters.

When the energy storage system is powered on, on the LCD screen of the inverter, enter the **SETUP** page and set these common parameters:

- Step 1.** Set the language of the integrated EMS. For more information, see [LANGUAGE](#).
- Step 2.** Select the grid standard. For more information, see [GRID STD](#).
- Step 3.** Set the working mode of the system. For more information, see the [WORK MODE](#) subsection under [SYS SETTING](#).
- Step 4.** Set the date and time of the system. For more information, see [DATE/TIME](#).
- Step 5.** If external CTs are connected, run the CT self-check. For more information, see [CT SELF CHK](#).

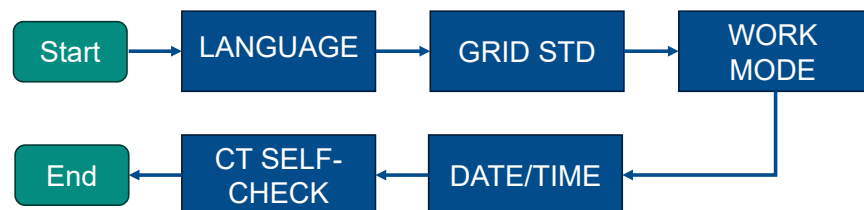

Figure 5-2 Set Common Parameters

If you want to set more parameters for the system, see [Setting up the System](#).

5.4 Checking the Settings

When the energy storage system is powered on, check the settings of the battery pack, PV, and grid to make sure that the system can work correctly.



To calibrate the SOC of the battery, after the system is installed, the batteries must be charged to 100% SOC once.

Step 1. Follow these steps to check the battery information:

- 1.1 Turn on the battery packs. For more information, see [Turning on a Battery Pack](#).



Make sure no red indicator light is ON.

- 1.2 Open the side covers of the battery packs and turn on the DC Switches.
- 1.3 Inside the cable box, turn on the Battery Switch.
- 1.4 5–10 seconds after the LCD screen on the inverter is turned on, check the information on the **BATTERY** page and the **BMS PARAM** page. For more information, see [Viewing the Current System Information](#).
 - Temperature: Depends on the ambient temperature around the system.
 - Voltage: Must be within the 50 V ± 3 V range.
 - Capacity: The capacity of a battery is 100 AH. When more than one battery pack is connected in parallel, the capacity of the system is 100 AH multiplied by the number of battery packs.

Step 2. After PV input is connected and the external PV Switch is turned on, check the information on the **PV1 INPUT , PV2 INPUT and the PV3 INPUT page**. For more information, see [Viewing the Current System Information](#).

Step 3. After ON GRID connection is done, check the information on the **GRID VOLT** page. For more information, see [Viewing the Current System Information](#).

5.5 Powering off

WARNING

To prevent damage or personal injury, after the equipment is turned off, DO NOT begin maintenance work until 5 minutes have passed.

Step 1. If backup loads are applied, turn off the LOAD Switch inside the cable box.

- Step 2.** Inside the cable box, turn off the Battery Switch.
- Step 3.** Open the side cover of the battery pack and turn off the DC Switch.
- Step 4.** Turn off the battery packs. For more information, see [Turning off a Battery Pack](#).
- Step 5.** Turn off the AC current breaker between GRID port and the grid.
- Step 6.** Close the side covers of the battery packs and the cover of the cable box.

6 System Operation

6.1 Restarting the System

If necessary, follow these steps to restart the system:

Step 1. Power off the system. For more information, see [Powering off](#).

Step 2. Power on the system. For more information, see [Powering On](#).

6.2 Viewing the Current System Information



Some parameter names shown on the integrated EMS page are abbreviated to fit the LCD display size.

Information shown on the screen is for reference only. It may vary depending on the software version.

When the inverter is ON, the LCD screen on the inverter automatically shows these pages, one after another:

- **DC VOLTAGE:** Shows the bus voltage.
- **BATTERY:** Shows the voltage, current, and capacity of the battery.
- **BMS PARAM:** Shows the battery type, temperature, SOC, charge voltage, charging current, and discharging current.
- **GRID VOLT, GRID CURR, GRID FREQ, INV VOLT, INV CURR, INV FREQ, BACKUP VOLT, and BACKUP CURR:** Shows the voltage of the R, and S phases.
- **POWER:** Shows the power of the inverters, the grid, the normal loads, the PV, the backup loads, and the battery.
- **TEMPERATURE:** Shows the temperature of the inverter, the DC-DC converter (LLC) inside the inverter, the environment, the PV, and the LLC circuit module.
- **STATE:** Shows the state of the system, the inverter circuit inside the inverter, and the DC-DC converter.

Parameter Name	Value	Description
SYS	INIT	Means the system is being initialized. This state occurs when the system is being powered on and the ARM chip is not communicating with the DSP chip.
	Standby	Means the main power circuit is not ON.
	Hybrid-G	Means the system is being connected to the grid.
	Off-grid	Means the system is off grid.
	G-charge	Means the system is charged by the power grid.
	P-charge	Means the system is charged by the PV panels.
	G-bypass	Means the power grid is being bypassed.
	Error	Means an error has occurred.
INV	Standby	Means the inverter circuit is on standby.
	Off-grid	Means the inverter circuit is off grid.
	Para	Means the inverter is being connected to the grid.
	Off to para	Means the inverter is in transition from off-grid to on-grid.
	Para to off	Means the inverter is in transition from on-grid to off-grid.
DCDC	Standby	Means the DC-DC converter is on standby.
	Soft star	Means the DC-DC converter is in soft-start.
	Charge	Means the DC-DC converter is in charging mode.
	Discharge	Means the DC-DC converter is in discharging mode.

- **ERROR NO.:** Shows the warning code and error code.
- **SYSTEM:** Shows the selected working mode, the selected grid standard, and the PV input mode.
- **PV1 INPUT:** Shows the input voltage, current, and power on the PV1 ports.
- **PV2 INPUT:** Shows the input voltage, current, and power on the PV2 ports.
- **PV3 INPUT:** Shows the input voltage, current, and power on the PV3 ports.

6.3 Setting up the System









The inverter incorporates an energy management system (EMS). You can use the LCD screen on the inverter to operate the integrated EMS to set the parameters. For more information about the buttons on the inverter, see [LCD Screen](#).



Information shown on the screen is for reference only. It may vary depending on the software version.

6.3.1 Go to **SETUP**



Follow these steps to go to the **SETUP** page to set or view the parameters:

- Step 1.** When the LCD screen on the inverter shows different information items one after another, press  to go to the **USER** page.
- Step 2.** On the **USER** page, press  or  to move the cursor to **SETUP** and then press .
- Step 3.** On the **PASSWORD** page, enter your password by pressing  or  to change the digits.
For the first log-in, use the default password **00000**. To change the password, see [PASSWORD](#).
- Step 4.** On the **SETUP** page, press  or  to move the cursor and then press  to select a parameter group to set:
- **SYS SETTING**: To set the configuration of the system. See [SYS SETTING](#).
 - **BAT SETTING**: To set the configuration of the batteries. See [BAT SETTING](#).
 - **GRID STD**: To select a grid standard. See [GRID STD](#).
 - **RUN SETTING**: To set the configuration to run the system. See [RUN SETTING](#).
 - **485 ADDRESS**: To set the parameters for RS485 communication. See [RS485 ADDRESS](#).
 - **BAUD RATE**: To set baud rate for data transmission. See [BAUD RATE](#).



- **LANGUAGE:** To set the language of the integrated EMS. See [LANGUAGE](#).
- **BACK LIGHT:** To set the duration before the screen backlight automatically turns off. See [BACK LIGHT](#).
- **DATE/TIME:** To set the date and time shown on the system. See [DATE/TIME](#).
- **CLEAR REC:** To clear the records. See [CLEAR REC](#).
- **PASSWORD:** To change the password. See [PASSWORD](#).
- **MAINTENANCE:** For maintenance personnel only. See [MAINTENANCE](#).
- **CT SELF CHK:** To run a CT self-check. See [CT SELF CHK](#).

When the settings are done, you can press  to leave the current setting page.

6.3.2 SYS SETTING

On the **SETUP** page, press  or  to move the cursor to select **SYS SETTING** and then press  to view and set parameters of the system.

WORK MODE

On the **SYS SETTING** page, press  or  to move the cursor to select **WORK MODE** and press  to set a working mode.

The E8KD/E10KD/E12KD/E15KD supports three working modes: SELF CONSUME, PEAK SHIFT, and BAT PRIORITY. For more information, see [Working Modes](#).

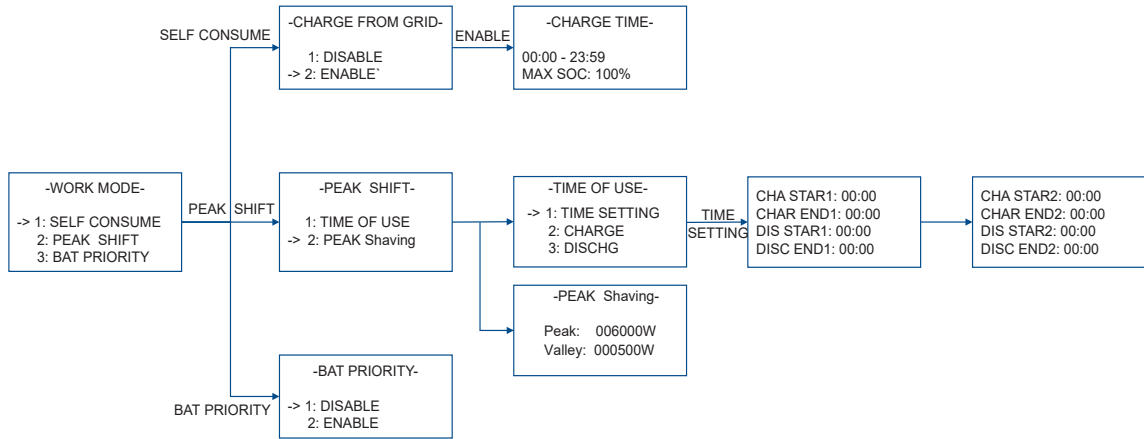

- **SELF CONSUME:** This is the default working mode. In this mode, the batteries are charged by the PV panel by default.

On the **WORK MODE** page, press or to move the cursor to select **SELF CONSUME** and then press . On the **CHARGE FROM GRID** page, you can enable the batteries to be charged by the grid. When **CHARGE FROM GRID** is enabled, you can set the time and the maximum SOC for charging. Charging will automatically stop when the set time or **MAX SOC** is reached.

- **PEAK SHIFT:** On the **WORK MODE** page, press or to move the cursor to select **PEAK SHIFT** and then press .

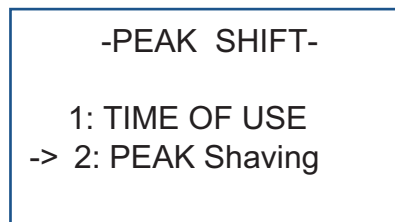

- On the **PEAK SHIFT** page, you can select **TIME OF USE** or **Peak Shaving**.

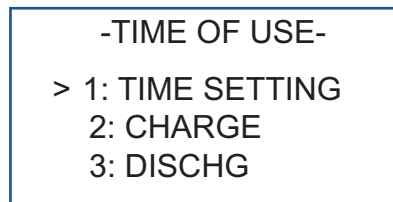



- On the **TIME OF USE** page, you can set times for charging and discharging (up to two each), and then press or to move the cursor to select **CHARGE** or **DISCHR** to charge or discharge the battery. During the charging time, the batteries are forced to be charged by the grid and/or the PV panels. During the discharging time, the batteries are forced to be discharged to the connected load.

-PEAK Shaving-



Peak: 006000W

Valley: 000500W

- On the **Peak Shaving** page, you can set peak power and valley power of grid.
- Peak power: The factory default value is **006000W**. The value ranges from 500 to 200000W.
- Valley power: The factory default value is **000500W**. The value ranges from 0 to 199999W.
- The value of **Valley** must be lower than the value of **Peak**.
- **BAT PRIORITY**: To enable this mode, go to the **WORK MODE** page and press  or  to move the cursor to select **BAT PRIORITY**, and then press .

PV INPUT

There are two modes for PV inputs: independent and parallel. Set the appropriate PV input mode based on the actual connection of the PV strings.

On the **SYS SETTING** page, press  or  to move the cursor to select **PV INPUT** and press  for settings.

The default setting is **INDEPENDENT**. If independent mode is selected when the PV strings are actually connected in parallel, it results in an imbalanced distribution of power in the PV strings.



-PV INPUT-

-> 1: INDEPENDENT

2: PARALLEL

ZERO EXPORT

The E8KD/E10KD/E12KD/E15KD can output power to the grid.

On the **SYS SETTING** page, press  or  to move the cursor to select **ZERO EXPORT** and press .

By default, this feature is disabled. When the feature is enabled, the system outputs power to the grid and you can set the power limit in the range from 10 W to the rated power of the system.

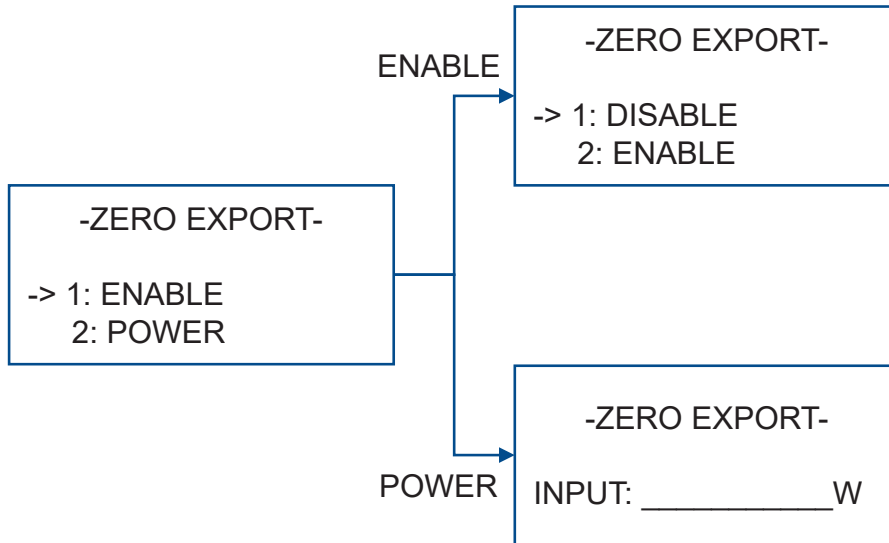

EPS ENABLE

On the **SYS SETTING** page, press or to move the cursor to select **EPS ENABLE** and press .

By default, the E8KD/E10KD/E12KD/E15KD can automatically switch to backup power when a grid power failure occurs.

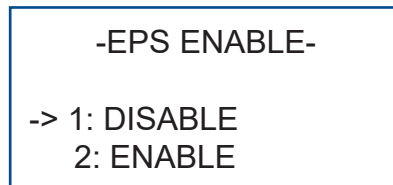

REMOTE CTRL

You can control the system through RS485 communication.

On the **SYS SETTING** page, press or to move the cursor to select **REMOTE CTRL** and press .

By default, this feature is disabled.

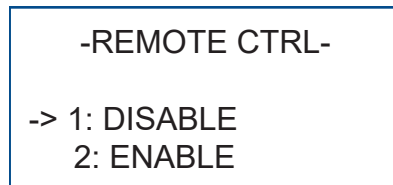

GFCICLK ENB

The E8KD/E10KD/E12KD/E15KD supports a connection of ground failure circuit interrupter to monitor the AC grid connection.

On the **SYS SETTING** page, press or to move the cursor to select

GFCICHK ENB and press .



By default, this feature is enabled.

-GFCICHK ENB-

-> 1: DISABLE
2: ENABLE

DOD ENABLE

DOD means Depth of Discharge. Enabling DOD can prevent the battery from discharging to 0%.

On the **SYS SETTING** page, press  or  to move the cursor to select **DOD ENABLE** and press .

By default, DOD is enabled.





Disabling DOD is not recommended.

-DISCHG DEPTH-

-> 1: DISABLE
2: ENABLE

GENERATOR

You can use a generator, for example, a wind generator or a diesel generator, as a backup supply to the E8KD/E10KD/E12KD/E15KD energy storage system.

On the **SYS SETTING** page, press  or  to move the cursor to select **GENERATOR** and press  to enable the generator mode.



By default, this feature is disabled. When the grid power is not available, you can manually enable the generator mode and connect the load to the generator.

-GENERATOR-

-> 1: DISABLE
2: ENABLE

CT OR METER

The E8KD/E10KD/E12KD/E15KD support connecting external CTs or a smart meter for measuring the energy consumption.

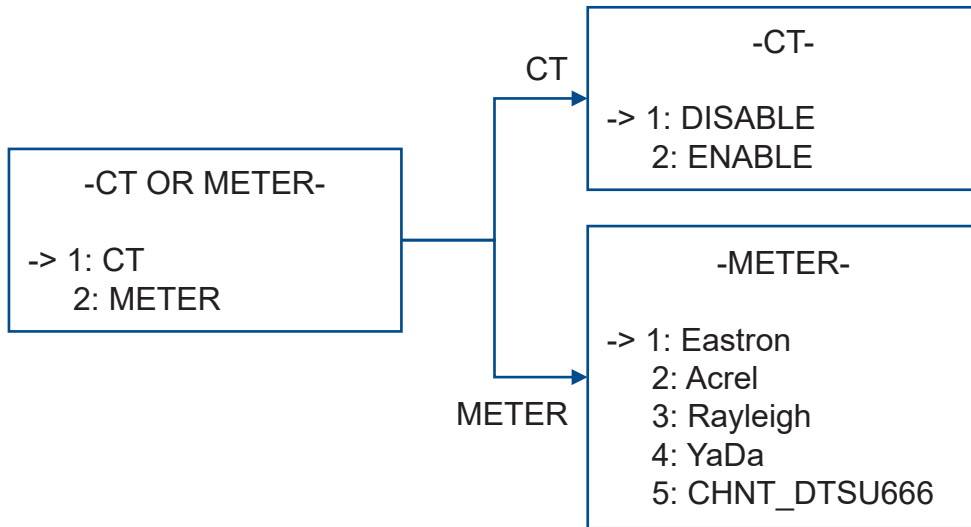

On the **SYS SETTING** page, press  or  to move the cursor to select **CT OR METER** and press .

By default, **CT** is selected. If you want to connect a smart meter, five brands are supported currently. The CHNT DTSU666 250A/50mA is recommended.



AC COUPLE

If you want to connect an inverter to your PV panels to build an AC-coupling system, you must enable **AC COUPLE**.

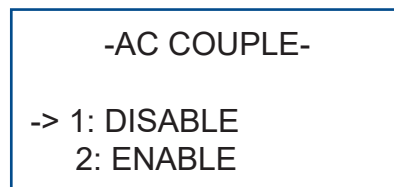

On the **SYS SETTING** page, press  or  to move the cursor to select **AC COUPLE** and press .

By default, this feature is disabled. For more information, see [AC-coupling System](#).



PARALLEL

When more than one inverter is installed in parallel, you must enable **PARALLEL** and set the addresses for the inverters.

On the **SYS SETTING** page, press  or  to move the cursor to select **PARALLEL** and press .

When a parallel system is installed and **PARALLEL** is enabled, assign an address (a value from 1 to 4) to each inverter. The address of the primary inverter must be set to 1. A maximum of four inverters are supported. For more information, see [Installing a Parallel System](#).

By default, this feature is disabled.

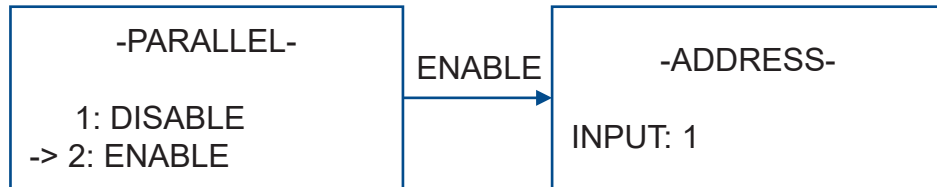

Demand Ctrl

The E8KD/E10KD/E12KD/E15KD has an Demand Ctrl feature.

On the **SYS SETTING** page, press or to move the cursor to select **Demand Ctrl** and press .

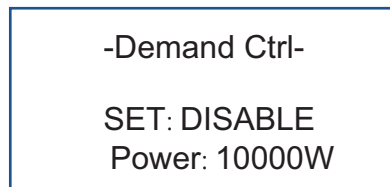

By default, this feature is disabled. When it is enabled, you can set the power to be drawn from the grid. The factory default value is **10000W**. The value ranges from 0 to 60KW

6.3.3 BAT SETTING

On the **SETUP** page, press or to move the cursor to select **BAT SETTING** and then press to view and set the configurations of the batteries.

BAT TYPE

On the **BAT SETTING** page, press or to move the cursor to select **BAT TYPE**, and press .

Currently, only **LFP** batteries are supported. After selecting **LFP**, you must restart the system. For more information, see [Restarting the System](#).

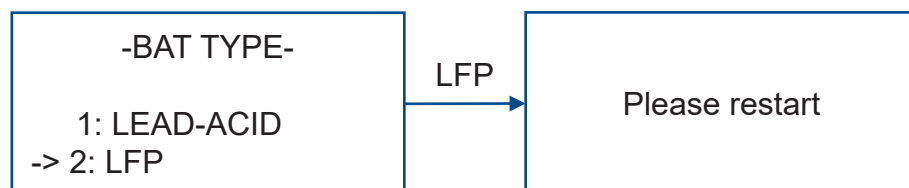

DISC DEPTH

When the E8KD/E10KD/E12KD/E15KD energy storage system is connected to the power grid, you can set the maximum depth of discharge of batteries.



On the **BAT SETTING** page, press  or  to move the cursor to select **DISC DEPTH**, and press .

The range for this parameter is 10–95%, and the default value is **90%**.

-DISC DEPTH-
INPUT: _____
UNIT: %

CHG CURR

You can set the maximum battery charging current.

On the **BAT SETTING** page, press  or  to move the cursor to select **CHG CURR**, and press .



E8KD/E10KD: The range for this parameter is 1–160 A. The default value is 160 A.

E12KD/E15KD: The range for this parameter is 1–200 A. The default value is 200 A.

-CHG CURR-
INPUT: _____
UNIT: A

DISC POWER

You can set a maximum discharge power, expressed as a percentage of the rated output power.



On the **BAT SETTING** page, press  or  to move the cursor to select **DISC POWER**, and press .

The range for this parameter is 0–100%. The default value is **100%**.

-DISC PERCENT-
INPUT: ____%

CHG POWER

You can set a maximum charge power, expressed as a percentage of the rated output power.

On the **BAT SETTING** page, press  or  to move the cursor to select **CHG POWER**, and press .



The range for this parameter is 1–100%. The default value is **100%**.

-CHAR PERCENT-

INPUT: ____%

BAT END VOLT

You can set a voltage as the end-of-discharge voltage. During discharging, when the set end-of-discharge voltage is reached, it means 0% of voltage has been reached and discharging is stopped.

On the **BAT SETTING** page, press  or  to move the cursor to select **BAT END VOLT**, and press .

The range for this parameter is 40–48 V. The default value is **43.2 V**.

-BAT END VOLT-

INPUT: _____



UNIT: V





BAT WAKE-UP

The battery will go to sleep in these states:

- Over-discharge protection.
- No communication between the battery and the external and no charging or discharging current for a period.

By default, the system monitors the SOC and DOD of the batteries. You can set the system to wake up the batteries from sleep and to check the SOC and DOD at a set interval.

On the **BAT SETTING** page, press  or  to move the cursor to select **BAT WAKE-UP** and press .

When the wake-up feature is enabled, on the **BAT WAKE-UP** page, press  or  to move the cursor to select **TIME**, press , and then press  or  to change the interval. The range for this parameter is 0–300 minutes.

You can disable the wake-up feature.

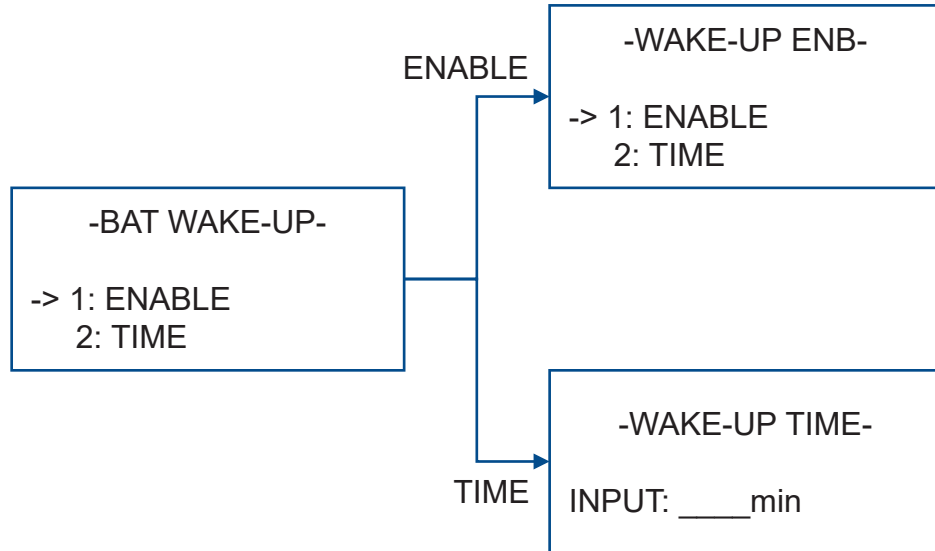

HEATING FILM

If you ordered and installed a heating film for the battery pack, you can decide whether to enable the heating film or not.

On the **BAT SETTING** page, press or to move the cursor to select **HEATING FILM** and press .

By default, the setting is **AUTOMATIC**. It means the film is automatically turned on or off based on the ambient temperature.

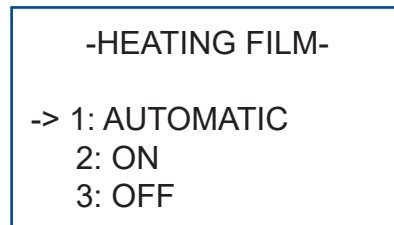

BMS DOD

On the **BAT SETTING** page, press or to move the cursor to select **BMS DOD** and press .

By default, BMS depth of discharge is disabled, and the inverter monitors the depth of discharge of the battery. Generally, DO NOT enable BMS DOD.

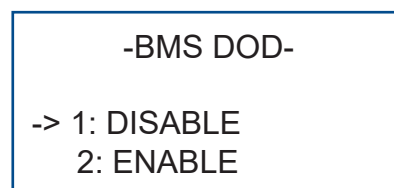

MAINTAIN SOC

On the **BAT SETTING** page, press  or  to move the cursor to select **MAINTAIN SOC** and press .



When MAINTAIN SOC is enabled, the minimum battery SOC is maintained. The minimum battery SOC is 2%. When the battery SOC is less than 2%, the grid charges the battery to 5% through the inverter.

-MAINTAIN SOC-

-> 1: DISABLE
2: ENABLE

FORCE WAKE



By default, a battery goes to sleep and is woken up at a set interval, but if you enable the **FORCE WAKE** feature, the battery will stay online and not go to sleep.

On the **BAT SETTING** page, press  or  to move the cursor to select **FORCE WAKE** and press .

-FORCE WAKE-

-> 1: DISABLE
2: ENABLE

6.3.4 GRID STD

On the **SETUP** page, press  or  to select **GRID STD** to select the grid standard that is applicable to your energy storage system. The default value is **SPLIT PHASE**

You can select the appropriate grid-connected power output mode in the integrated EMS: On the **SYS SETTING** page, press  or  to move the cursor to select **GRID TYPE** and press .

-GRID TYPE-

-> 1: Single-PH
2: Split-PH
3: Three-PH
4: Local
5: 60Hz



Other power grid modes in the power grid mode setting project are manufacturer test modes, Customers should select the corresponding power grid options according to the local power grid standards.

6.3.5 RUN SETTING

On the **SETUP** page, press or to move the cursor to select **RUN SETTING** and then press to view and set parameters the configurations to run the system.

REACT MODE

The E8KD/E10KD/E12KD/E15KD provide some ways to monitor reactive power. These settings are determined by the selected grid standard. You must not change these settings during system operation.

On the **RUN SETTING** page, press or to move the cursor to select **REACT MODE** and press .

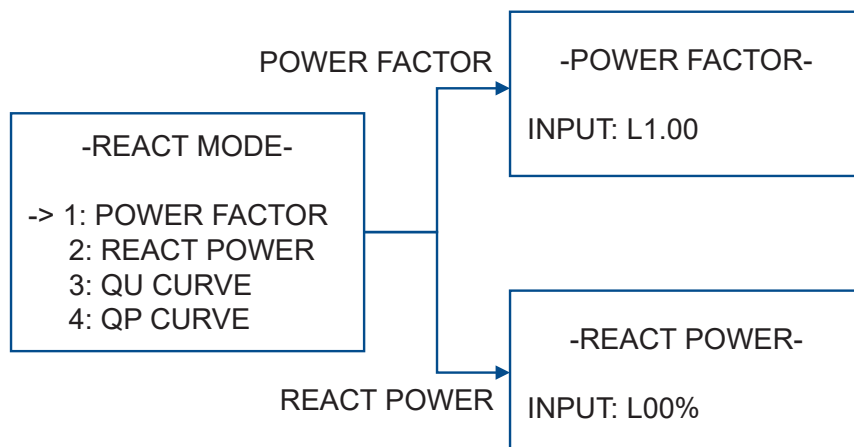

Here are the settings:

- **POWER FACTOR**: The acceptable range is L0.8–L1.00 and C0.8–C1.00. The default setting is PF1.0.
- **REACT POWER**: The acceptable range is L00%–L60% and C00%–C60%.
- **QU CURVE** and **QP CURVE**: By default, both are disabled.



GRID POWER

You can limit or increase the power output from the system to the grid.

On the **RUN SETTING** page, press  or  to move the cursor to select **GRID POWER** and press .



The setting value is a percentage of the rated power of the system. It can be set from 0% to 100%, and the default value is **100%**.

-GRID PERCENT-

INPUT: ___%

GRID U and GRID F

Table 6-1 lists the inverter parameters for **RUN SETTING**.

On the **RUN SETTING** page, press  or  to move the cursor to select **GRID U MAX**, **GRID U MIN**, **GRID F MAX**, or **GRID F MIN** and press .

When you select the grid standard in GRID STD, these parameters are set automatically. During operation, when the inverter detects that these settings have been reached or exceeded, the inverter stops generating power.



The Rated value depends on the GRID standard, If the GRID standard is SPLIT PHASE the Rated value is 240Vac; If the GRID standard is Three PHASE the Rated value is 208Vac.

Changing the setting of these parameters is not recommended.

After adjusting one or more parameters, follow the onscreen prompts and restart the system. For more information, see Restarting the System.



Table 6-1 GRID Parameters for Run Setting

Parameter		Description	Default
GRID U MAX	VOLT	Upper limit voltage	Rated value*110% VAC
	(S1)	Protection time	2000 ms
	VOLT	Upper limit voltage	Rated value*120% VAC
	(S2)	Protection time	160 ms

GRID U MIN	VOLT (S1)	Lower limit voltage	Rated value*70% VAC
		Protection time	1000 ms
	VOLT (S2)	Lower limit voltage	Rated value*45% VAC
		Protection time	160 ms
GRID F MAX	FREQ (S1)	Upper limit frequency	61.2 Hz
		Protection time	300 s
	FREQ (S2)	Upper limit frequency	62 Hz
		Protection time	160 ms
GRID F MIN	FREQ (S1)	Lower limit frequency	58.5 Hz
		Protection time	300 s
	FREQ (S2)	Lower limit frequency	56.5 Hz
		Protection time	160 ms

BYPASS U and BYPASS F

Table 6-2 lists the grid bypass parameters for **RUN SETTING**.

On the **RUN SETTING** page, press  or  to move the cursor to select **BYPASS U MAX**, **BYPASS U MIN**, **BYPASS F MAX**, or **BYPASS F MIN** and press .

When the inverter is in grid bypass output state:

- When the grid voltage is in the range from **BYPASS U MIN** to **BYPASS U MAX**, or the grid frequency is in the range from **BYPASS F MIN** to **BYPASS F MAX**, the backup voltage is equal to the grid voltage.
- When the grid voltage is higher than **BYPASS U MAX** or lower than **BYPASS U MIN**, or the grid frequency is higher than the **BYPASS F MAX** or lower than **BYPASS F MIN**, the backup load turns off the output. This means the backup voltage is 0 V.

When you select the grid standard in **GRID STD**, these parameters are set automatically. During operation, when the inverter detects that these settings have been reached or exceeded, the inverter stops generating power.

BYPASS U MAX the default is Rated value*120% VAC.

BYPASS U MIN the default is Rated value*45% VAC.

BYPASS F MIN the default is 56.5Hz. **BYPASS F MAX** the default is 62Hz.



Changing the setting of these parameters is not recommended.
After adjusting one or more parameters, follow the onscreen prompts and restart the system. For more information, see [Restarting the System](#).

Table 6-2 BYPASS Parameters for Run Setting

Parameter	Description	Default
BYPASS U MAX	Maximum voltage of the grid	290 VAC
BYPASS U MIN	Minimum voltage of the grid	0 VAC
BYPASS F MAX	Maximum frequency of the grid	66 Hz
BYPASS F MIN	Minimum frequency of the grid	44.5 Hz

OVER VOLT and UNDER VOLT

On the **RUN SETTING** page, press or to move the cursor to select **OVER VOLT** or **UNDER VOLT** and press .



When you select the grid standard in **GRID STD**, these parameters are set automatically.





Changing the settings of these parameters is not recommended.
After adjusting one or more parameters, you must restart the system. For more information, see [Restarting the System](#).

By default, **OVER VOLT** and **UNDER VOLT** are disabled. You can enable them and set the voltages:

- **OVER VOLT**: When it is enabled, you can set **VOLT**. If the AC output voltage is higher than the set value, the output power decreases. The default value of **VOLT** is Rated value*110% VAC. You can press or to increase or decrease the value.
- **UNDER VOLT**: When it is enabled, you can set **VOLT**. If the AC output voltage is lower than the set value, the output power decreases. The default value of **VOLT** is Rated value*106% VAC . You can press or to increase or decrease the value.

- In the **OVER VOLT** and **UNDER VOLT** range, the power will change from 0 to 100%.
- **OVER VOLT** and **UNDER VOLT** Configurable range: 208Vac to 290Vac.
- You can set **OVER VOLT** and **UNDER VOLT** response time by setting T. The configurable range of T is 0-65s. You can press  or  to increase or decrease the value.

OVER FREQ and UNDER FREQ





On the **RUN SETTING** page, press  or  to move the cursor to select **OVER FREQ** or **UNDER FREQ** and press .

When you select the grid standard in **GRID STD**, these parameters are set automatically.





Changing the setting of these parameters is not recommended. After adjusting one or more parameters, you must restart the system. For more information, see [Restarting the System](#).

By default, **OVER FREQ** and **UNDER FREQ** are disabled. You can enable them and set the frequencies:

- **OVER FREQ**: When it is enabled, you can set **FREQ**. If the AC output frequency is higher than the set value, the output power decreases. The default value of **FREQ** is 60.04 Hz. Change slope is 0.050 Hz. Response time can be set within a range 0-5000ms. You can press  or  to increase or decrease the value.
- **UNDER FREQ**: When it is enabled, you can set **FREQ**. If the AC output frequency is lower than the set value, the output power decreases. The default value of **FREQ** is 59.96 Hz. Change slope is 0.050 Hz. Response time can be set within a range 0-5000ms. You can press  or  to increase or decrease the value.

VRT ENABLE

VRT ENABLE is to enable or disable voltage-ride-through.

On the **RUN SETTING** page, press  or  to move the cursor to select **VRT ENABLE** and press .

When you select the grid standard in **GRID STD**, **VRT ENABLE** is set automatically.



Changing the setting of **VRT ENABLE** is not recommended.

POW SI RATE

POW SI RATE means the change of output power per minute.

On the **RUN SETTING** page, press or to move the cursor to select **POW SI RATE** and press .

The selected grid standard determines the rate, so **DO NOT** change it if the grid is not changed. The value of 100% means that the output power can reach the rated power within one minute. The range for this parameter is 0% to 300%, and the default value is **100%**.

-POW SI RATE-

INPUT: ___%

PV START

You can set the PV start voltage.

On the **RUN SETTING** page, press or to move the cursor to select **PV START** and press .

The default value is 150 V, and you can press or to increase or decrease the value in the range from 120 V to 480 V.

QU Point

You can set the QU Point.

On the **RUN SETTING** page, press or move the cursor to select **QU POINT** and press .

When you select the grid standard in **GRID STD**, these parameters are set automatically. The selected grid standard determines the value, so **DO NOT** change it if the grid is not changed.

U1:092%	Q: C05.6%
U2:098%	Q: C00.0%
U3:102%	Q: L00.0%
U4:108%	Q: L05.6%

The default value is:

U1:092% Q: C05.6%;



U2:098% Q: C00.0%;

U3:102% Q: L00.0%;

U4:108% Q: L05.6%.

QU Time & PF



You can set the QU Time & PF.

On the **RUN SETTING** page, press  or  to move the cursor to select **QU TIME&PF** and press .

When you select the grid standard in **GRID STD**, these parameters are set automatically. The selected grid standard determines the value, so **DO NOT** change it if the grid is not changed.



- QU TIME&PF -	
QU1:	DISABLE
Time:	5000ms
VRef:	1000.0%

The default value is Time:5000ms; VRef:100.0%.

You can press  or  to increase or decrease the value in the range:
Time:0-9999ms; VRef:00.0%-100.0%.

QU Auto



You can set the QU Auto.

On the **RUN SETTING** page, press  or  to move the cursor to select **QU AUTO** and press .

When you select the grid standard in **GRID STD**, these parameters are set automatically. The selected grid standard determines the value, so **DO NOT** change it if the grid is not changed.



- QU Auto -	
Set:	DISABLE
Time:	00300s

The default value is Time:00300s.

You can press  or  to increase or decrease the value in the range:
Time:0-99999s.

QU Set



You can set the QU Auto.

On the **RUN SETTING** page, press  or  to move the cursor to select QU SET and press .



When you select the grid standard in **GRID STD**, these parameters are set automatically. The selected grid standard determines the value, so **DO NOT** change it if the grid is not changed.

- QU Set -	
QU:	DISABLE
Time:	50000ms
VRef:	100.0%

The default value is Time:50000ms.

You can press  or  to increase or decrease the value in the range:
Time:0-99999ms.



QP Set

On the **RUN SETTING** page, press  or  to move the cursor to select QP Set and press .

When you select the grid standard in **GRID STD**, these parameters are set automatically. The selected grid standard determines the value, so **DO NOT** change it if the grid is not changed.

- QP Set -	
Set:	DISABLE
Time:	00300s

The default value is Time:00300s.

You can press  or  to increase or decrease the value in the range:
Time:0-99999s.

QP Generate

You can set the QP Generate.

On the **RUN SETTING** page, press  or  to move the cursor to select **QP GENERATE** and press .

When you select the grid standard in GRID STD, these parameters are set automatically. The selected grid standard determines the value, so DO NOT change it if the grid is not changed.



- QP Generate -	
P1:020%	Q1:L000%
P2:050%	Q2:L000%
P3:100%	Q3:L000%

The default value is:

P1:020% Q1:L000%;
P2:050% Q2:L000%;
P3:100% Q3:L000%.

QP Absorb

You can set the QP Absorb.

On the RUN SETTING page, press  or  to move the cursor to select QP Absorb and press .

When you select the grid standard in GRID STD, these parameters are set automatically. The selected grid standard determines the value, so DO NOT change it if the grid is not changed.

- QP Absorb -	
P1:000%	Q1:C000%
P2:050%	Q2:C000%
P3:100%	Q3:C000%



The default value is:

P1:000% Q1:C000%;

P2:050% Q2:C000%;

P3:100% Q3:C000%.

ES Set

On the **RUN SETTING** page, press  or  to move the cursor to select ES and press .

When you select the grid standard in **GRID STD**, these parameters are set automatically. The selected grid standard determines the value, so **DO NOT** change it if the grid is not changed.

VoltHigh:	231.0V
VoltLow:	201.7V
FreqHigh:	60.1Hz
FreqLow:	59.5Hz

The default value is:



VoltHigh:231.0V;

VoltLow:201.7V;

FreqHigh:60.1Hz;

FreqLow:59.5Hz.

ES Enable & T

On the **RUN SETTING** page, press  or  to move the cursor to select ES ENABLE&T and press .

When you select the grid standard in **GRID STD**, these parameters are set automatically. The selected grid standard determines the value, so **DO NOT** change it if the grid is not changed.



Service:	ENABLE
Delay:	0300s
Random:	0000s
RampTime:	00300s

The default value is:

Delay:0300s;

Random:0000s;

RampTime:0300s.



You can press  or  to increase or decrease the value in the range:

Delay:0 to 9999s;

Random:0 to 9999s;

RampTime:0 to 9999s.

10 min Vac

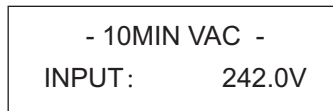

On the **RUN SETTING** page, press  or  to move the cursor to select 10 MIN VAC and press .

When you select the grid standard in **GRID STD**, these parameters are set automatically. The selected grid standard determines the value, so **DO NOT** change it if the grid is not changed.



The default value is 242.0V.

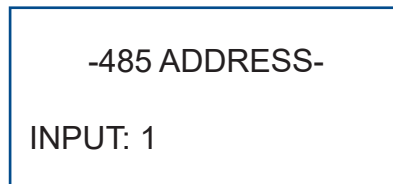

6.3.6 RS485 ADDRESS

On the **SETUP** page, press  or  to select **RS485 ADDRESS** to set the RS485 address for the COM port. By default, the address is 1, and you can set it to any value from 1 to 32.





6.3.7 BAUD RATE

Obtain the baud rate of the COM port of the upper computer and set the same baud rate for the COM port of the inverter.

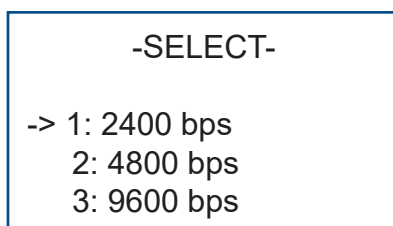
On the **SETUP** page, press  or  to select **BAUD RATE** to set the baud rate of the RS485 communication for the COM port. It can be set to 2400 bps, 4800 bps, or 9600 bps. The default value is 9600 bps.





6.3.8 LANGUAGE

On the **SETUP** page, press  or  to select **LANGUAGE** to set the display language. By default, the language is English and you can change it to 中文 (Chinese) or French.

```
-LANGUAGE-  
-> 1: 中文  
    2: English  
    3: French
```

6.3.9 BACK LIGHT

On the **SETUP** page, press  or  to select **BACK LIGHT** to set how long the backlight stays on at a time. By default, the backlight stays on for 20 seconds at a time. The range for this parameter is 20–120 seconds.

When the backlight is off, press any button to turn it on.



```
-LIGHT TIME-  
INPUT: _____  
UNIT: SEC
```

6.3.10 DATE/TIME

On the **SETUP** page, press  or  to select **DATE/TIME** to set the date, time, and day of the week for the system.

```
-DATE/TIME-  
DATE: YYYY-MM-DD  
TIME: hh:mm:ss  
WEEK: SUNDAY
```

6.3.11 CLEAR REC

On the **SETUP** page, press  or  to select **CLEAR REC** to clear all records. After the records are cleared, you cannot find any information in **INQUIRE**. For more information about records, see [Viewing INQUIRE](#).

```
-DEL REC-  
-> 1: CANCEL  
    2: CONFIRM
```

6.3.12 PASSWORD



It is recommended that you change the password immediately after the installation.

On the **SETUP** page, press or to select **PASSWORD** to change the password.

Follow these steps:

- Step 1.** On the **SETUP** page, press or to select **PASSWORD**.
- Step 2.** On the **OLD** row of the **PASSWORD** page, press or to change the digits to the old password. The default password is **00000**.
- Step 3.** On the **NEW** row of the **PASSWORD** page, press or to change the digits to a new password.
- Step 4.** On the **CONFIRM** row of the **PASSWORD** page, press or to change the digits to the new password again to confirm the change.

-PASSWORD-	
OLD:	-----
NEW:	-----
CONFIRM:	-----

6.3.13 MAINTENANCE

MAINTENANCE is for use by maintenance personnel only.

On the **SETUP** page, press or to select **MAINTENANCE** and press .
On the **MAINTAIN** page, three options are available:

- **CLEAR ENERGY:** To clear data.
- **AGEING:** This feature is inaccessible.
- **ISLAND:** To enable anti-islanding protection. This is for use by maintenance personnel only.

6.3.14 CT SELF CHK

When three external CTs are connected to the inverter, you can run a CT self-check. A CT self-check lasts 1–5 minutes.

Before running a CT self-check, make sure that all these operations are done:

Step 1. Connect external CTs. For more information, see [Connecting External CTs](#).

Step 2. Connect the inverter to the battery packs and the power grid.



On the **SETUP** page, press  or  to select **CT SELF CHK** and press .



These errors can occur during a CT self-check:

- **battery loss, fail to check:** Means no battery packs are connected to the system, so the CT self-check cannot be completed. You must connect battery packs and try the CT self-check again.
- **grid loss, fail to check:** Means the system is not connected to the grid, so the CT self-check cannot be completed. You must connect the system to the grid and try the CT self-check again.
- **CT loss, fail to check:** Means no external CTs are connected to the system, so the CT self-check cannot be completed. You must connect external CTs to the system and try the CT self-check again.
- **Timeout, fail to check:** Means the CT self-check timeout. Make sure that limits have not been placed on the charging and discharging power, because the power on each phase of the grid must be greater than 1 kW during a CT self-check. To achieve this, **DISC POWER**, **CHG POWER**, and **GRID POWER** must be set to **100%** and **CHG CURR** must be set to 160 A. For more information, see the [DISC POWER](#), [CHG POWER](#), and [CHG CURR](#) subsections under [BAT SETTING](#), and the [GRID POWER](#) subsection under [RUN SETTING](#).

6.4 Viewing INQUIRE

You can view the information of the E8KD/E10KD/E12KD/E15KD energy storage system. On the **USER** page, press  or  to select **INQUIRE** to view this information:

- **INV MODEL:** The model of the hybrid inverter in use.
- **MODEL SN:** The serial number of the hybrid inverter in use.
- **FIRMWARE:** The version of the firmware in ARM, DSP, and DSP2.
- **RECORD:** The errors of the system. You can view the last 500 errors. The earliest errors are automatically overwritten when more than 500 errors occur.
- **BMS INFO:** The information and the states of the connected battery packs, including:

- **VERSION:** The version of the BMS.
- **CYCLE CNT:** The number of battery cycles.
- **PROTECT, WARN CODE, and FAULT CODE:** The codes sent by the BMS to the inverter. You should contact Customer Service for more information about these codes.
- **METER STATUS:** The communication state of the energy meter.
- **PARALLEL:** The states of the inverters and loads in a parallel system, including:
- **INVERTERx: OFFLINE or ONLINE.** When an inverter is connected in a parallel system and its PARALLEL feature is enabled, the inverter is **ONLINE**. Otherwise, the inverter is **OFFLINE**. For more information, see [Installing a Parallel System](#).
- **INVERTERx: INIT, Standby, Hybrid-G, Off-grid, G-charge, P-charge, G-bypass, or Error.** This shows the values of the SYS parameter shown on the **STATE** page on the LCD screen of the inverter with address x. For more information, see [Viewing the Current System Information](#).
- **INV-x:Ex:** The inverted power of the inverter with the address x.
- **Load-x:** The load power of the inverter with the address x.

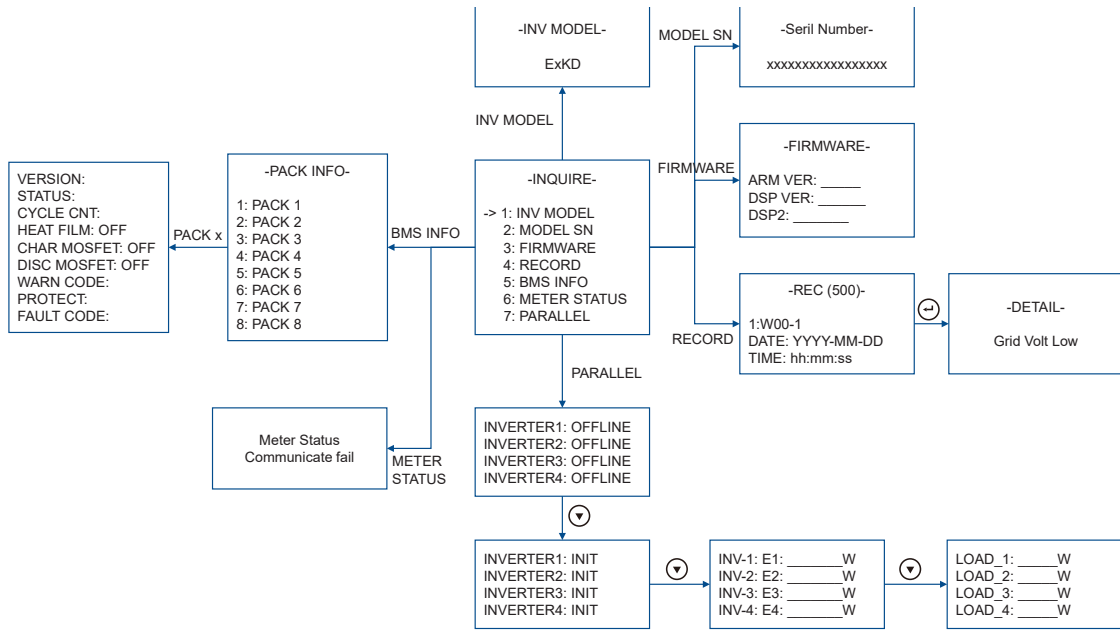

Figure 6-1 INQUIRE

6.5 Viewing STATISTIC

You can view some data of the E8KD/E10KD/E12KD/E15KD energy storage system.

On the **USER** page, press or to select **STATISTIC** to view this information:

- **TIME STAT:** Hours of the inverter running and its connection to the grid.
- **CONNE. TIMES:** Number of inverter connections to the grid.
- **PEAK POWER:** Total generation of watts and today’s generation of watts.
- **E-TODAY, E-MONTH, E-YEAR, and E-TOTAL:** The electricity generation for

the day, for the current calendar month, for the current calendar year, and since system installation, including the electricity generated by the PV panels, the electricity sold to the grid, the electricity purchased from the grid, and the power consumption of the loads.

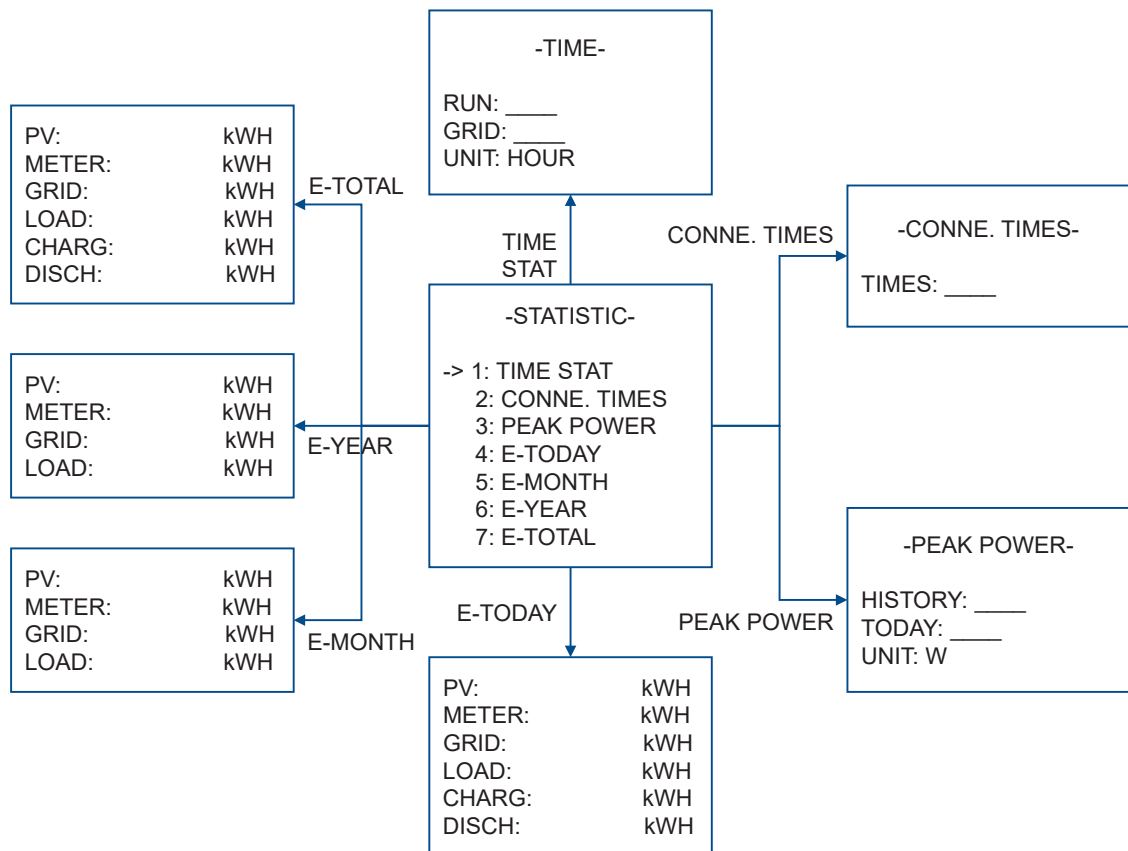
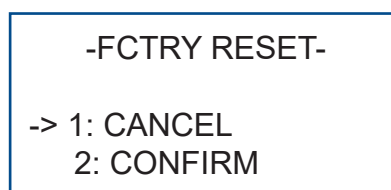

Figure 6-2 Statistics of the System

6.6 Restoring Factory Settings (FCTRY RESET)



You can reset the inverter to the default factory settings.

Step 1. On the **USER** page, press or to select **FCTRY RESET**.

Step 2. On the **PASSWORD** page, use or to enter your password.

Step 3. Press or to select **CONFIRM** and press .

6.7 Operating Battery Packs

6.7.1 Indicator Lights and States



The descriptions of the indicator lights and states of the battery pack in this section is applicable to BMS firmware version 1.1257 and later only.

A battery pack can be in five states: **OFF**, **NORMAL**, **ALARM**, **FAULT**, and **PROTECTION**. In each state, the battery pack can operate in different modes.

In an operation mode, the indicator lights have different blink modes: **ONCE**, **TWICE**, and **THREE**, as defined in [Table 6-3](#).

Table 6-3 Blink Modes of the Indicator Lights

	Blink Mode	Blink	OFF
ONCE	Blinks once every 4 seconds	0.25	3.75 s
TWICE	Blinks twice every 2 seconds	2 times of 0.25/0.25	1 s
THREE	Blinks three times every 3 seconds	3 times of 0.25/0.25	1.5 s

OFF State

When a battery pack is in the OFF state, all the indicator lights on the battery pack are OFF. To turn on the battery pack, see [Turning on a Battery Pack](#).

NORMAL State

When a battery pack is in the NORMAL state, the battery pack can be in any of three operation modes: IDLE, CHARGE, and DISCHARGE.

When the **OPERATION** indicator light blinks ONCE, and the **FAULT** indicator light is OFF, a battery pack is in the IDLE mode. In the IDLE mode, no current flows on the charging or discharging circuit and the SOC indicator lights show the battery level, as shown in [Table 6-4](#).

Table 6-5 Table 65 SOC Indicator Lights in IDLE Mode

SOC Level	SOC Indicator Lights (From Bottom to Top)			
0–25%	ON	OFF	OFF	OFF
26–50%	ON	ON	OFF	OFF
51–75%	ON	ON	ON	OFF
76–100%	ON	ON	ON	ON

When the **OPERATION** indicator light is ON, a battery pack can run in either CHARGE or DISCHARGE mode. The CHARGE mode generates charging current (current > 0) and the DISCHARGE mode generates discharging current (current

< 0). [Table 6-5](#) lists how the indicator lights work when a battery pack operates in the CHARGE and DISCHARGE modes.

Table 6-5 Indicator Lights in CHARGE and DISCHARGE Modes

Operation Mode	Indicator Lights					
	OPERATION	FAULT	SOC (From Bottom to Top)			
CHARGE to 0–25%	ON	OFF	TWICE	OFF	OFF	OFF
CHARGE to 26–50%	ON	OFF	ON	TWICE	OFF	OFF
CHARGE to 51–75%	ON	OFF	ON	ON	TWICE	OFF
CHARGE to 76–100%	ON	OFF	ON	ON	ON	TWICE
DISCHARGE to 0–25%	ON	ONCE	ON	OFF	OFF	OFF
DISCHARGE to 26–50%	ON	ONCE	ON	ON	OFF	OFF
DISCHARGE to 51–75%	ON	ONCE	ON	ON	ON	OFF
DISCHARGE to 76–100%	ON	ONCE	ON	ON	ON	ON

ALARM State, FAULT State, and PROTECTION State

A battery pack can be in the ALARM, the FAULT, or the PROTECTION state. Warnings are communicated through the SOC indicator lights and/or the codes shown on the LCD screen of the inverter. For more information, see [BMS ALARM Warnings](#), [BMS FAULT Warnings](#), and [BMS PROTECTION Warnings](#).

- ALARM:
 - When the **OPERATION** indicator light blinks ONCE, the **FAULT** indicator light blinks twice, the SOC indicator light at the bottom blinks TWICE or is ON, and the other SOC indicator lights are OFF, this indicates LOW SOC. This warning means the SOC level of the battery is lower than 5%. When this warning occurs, you must charge the battery. For more information, see [Recharging a Battery](#).
 - When the **OPERATION** indicator light blinks THREE times and the **FAULT** indicator light is OFF, this can indicate different things depending on the states of the SOC indicator lights. For more information, see [BMS ALARM Warnings](#).
- FAULT: When the **OPERATION** indicator light blinks THREE times and the **FAULT** indicator light is OFF, this indicates that a battery pack is in the FAULT state.

You can determine a FAULT warning from the states of the SOC indicator lights. For more information, see [BMS FAULT Warnings](#).

When a FAULT warning occurs, you must contact Customer Service.

- **PROTECTION:** When the **OPERATION** indicator light blinks THREE times and the **FAULT** indicator light is ON, a battery pack is in the PROTECTION state.

Different PROTECTION warnings can occur in the PROTECTION state. You can determine a PROTECTION warning by the states of the SOC indicator lights. For more information, see [BMS PROTECTION Warnings](#).

6.7.2 Turning on a Battery Pack

When the battery pack is in the OFF state, to turn on the battery pack, press the button on the battery pack, hold it for more than three seconds, and then release the button.

6.7.3 Turning off a Battery Pack

When the battery pack is in the NORMAL, ALARM, or PROTECTION state, to turn off the battery pack, press the button on the battery pack, hold it for more than three seconds, and then release the button.

6.7.4 Resetting a Battery Pack

When a battery pack is in the NORMAL, ALARM, FAULT, or PROTECTION state, to reset the battery pack, follow these steps:

Step 1. Inside the cable box, set the Battery Switch to the OFF position.

Step 2. Press the button on the battery pack, hold it for more than six seconds, and then release the button.

6.7.5 Expanding Battery Capacity

It is recommended that you expand battery capacity by adding batteries within one year of the system installation.

7 Maintenance

Both users and certified professional personnel must maintain the E8KD/E10KD/E12KD/E15KD energy storage system to ensure the healthy and safe operation of the system.

In this section, you can find the following:

- The inspection checklist for users of the energy storage system.
- The inspection checklist for professional personnel.
- Error codes, alarm codes, and the possible solutions of the system and the BMS.

7.1 Inspection Checklist for Users

Inspection Activity	Interval
Check for visible damage to any part of the system.	Six months
Check the inverter and battery packs for signs of wear and tear, heat damage, discoloration, and unusual smells.	Six months
Check the warning signs and guidance signs on the inverter and the battery pack for signs of wear and damage, and make sure none have been removed or obscured.	Six months
Check whether any part of the system makes an abnormal noise when the system is running.	Six months
Monitor the temperature of the battery pack and clean the battery pack if necessary.	Six months to a year
Make sure that the ground around the system is clean and tidy.	Six months to a year
Check the maintenance access to make sure that it is clear and unobstructed.	Six months to a year
When the system is running, check the voltage, temperature, and other parameters of the battery packs.	Six months
When the system is running, check the parameters of the inverters.	Six months
Check the battery packs for ineffectiveness or damage.	Six months

7.2 Inspection Checklist for Professional Personnel



- The equipment must be opened only by professional personnel that have been certified by COMPAny.
- During inspection and maintenance, wear protective personal equipment, including insulated gloves, protective shoes, and anti-noise earplugs.
- Follow local and international safety standards, regulations, and specifications to do the maintenance.
- Contact COMPAny promptly if you encounter anything not covered in this manual.

 **CAUTION**

Before maintenance, disconnect all the electrical connections. Wait at least five minutes after disconnection, so that the residual voltage of the capacitors falls to a safe voltage. Use a multi-meter to make sure that the equipment is completely discharged.

Inspection Activities	Interval
Check electrical connections for looseness.	Six months to a year
Check cables for deterioration or damage.	Six months to a year
Check cable terminal screws for looseness.	Six months to a year
Check cable terminals for signs of overheating.	Six months to a year
Check the ground connection.	Six months to a year
Check whether the cable tie is attached to the cable.	Six months to a year
Check the EMS, SOLARMAN app, and other related equipment for failure or damage.	Six months to a year

7.3 Troubleshooting

When you see an error code or alarm code on the LCD screen of the inverter, you can find possible solutions in this section. If the problem persists after trying these solutions, please contact COMPAny or an authorized distributor.

When a problem is successfully solved, the error code or alarm code on the LCD screen automatically disappears after a certain time delay, but you can always view it in the error records. For more information, see [Viewing INQUIRE](#).

7.3.1 Error Codes of the System

Code	Description	Possible Solutions
F00	Soft Time Out: Soft-start timeout.	Restart the inverter and wait until it runs correctly. If the code is still shown, contact Customer Service.
F01	INV Volt Short: The inverter output is shorted.	<ol style="list-style-type: none"> 1. Disconnect all power sources and shut down the inverters and the battery packs. 2. Disconnect the load. 3. Power on and restart all the inverters and the battery packs. 4. If no error is reported, it means the load is shorted. Check the load. If the code is still shown, contact Customer Service.
F02	GFCI Sensor Fault: A failure occurs to the Ground Fault Circuit Interrupter (GFCI) sensor.	<ol style="list-style-type: none"> 1. Disconnect all power sources. 2. Restart the inverter and wait until it runs correctly. If the code is still shown, contact Customer Service.
F04	Bus Volt Low: The bus voltage is low.	<ol style="list-style-type: none"> 1. Check the settings of the input mode. 2. Restart the inverter and wait until it runs correctly. If the code is still shown, contact Customer Service.
F05	Bus Volt High: The bus voltage is high.	If the code is still shown, contact Customer Service.
F06	Bus Short Circuit: The bus is shorted.	Restart the inverter and wait until it runs correctly. If the code is still shown, contact Customer Service.
F07	PV ISO Under Fault: The insulation resistance of a PV panel is low.	<ol style="list-style-type: none"> 1. Check the ground connection. 2. Check the ground resistance of PV+ and PV-: <ul style="list-style-type: none"> ▪ If the resistance is smaller than 2 MΩ, check the PV string for ground fault or poor ground insulation. If necessary, contact Customer Service. ▪ If the resistance is greater than 2 MΩ and the error code is still shown, contact Customer Service.

Code	Description	Possible Solutions
F08	PV Input Short Circuit: The PV input is shorted.	<ol style="list-style-type: none"> 1. Check the settings of the input mode. 2. Disconnect the PV input. 3. Restart the inverter and wait until it runs correctly. <p>If the code is still shown, contact Customer Service.</p>
F09	Bypass Relay Fault: A failure occurred to the bypass relay.	<ol style="list-style-type: none"> 1. Disconnect the PV input. 2. Restart the inverter and wait until it runs correctly.
F19	EPS Relay Fault: A failure occurred to the backup relay.	<p>If the code is still shown, contact Customer Service.</p>
F10	INV Curr Over: The output current on the inverter exceeds the threshold.	<ol style="list-style-type: none"> 1. Wait five minutes for the inverter to restart automatically. 2. Check the backup loads. If the load exceeds the rated output power of the inverter, disconnect some load. <p>If the code is still shown, contact Customer Service.</p>
F11	INV DC Over: The DC component of the output current of the inverter is too high.	<p>Restart the inverter and wait until it runs correctly.</p> <p>If the code is still shown, contact Customer Service.</p>
F12	Ambient Over Temp: The ambient temperature is too high.	<ol style="list-style-type: none"> 1. Restart the inverter. 2. Let the inverter cool for a few minutes and then restart it.
F13	Sink Over Temp: The temperature of the heat sink is too high.	<ol style="list-style-type: none"> 3. Observe whether the inverter can run correctly. 4. Make sure that the ambient temperature is in the range of -20°C to 55°C. <p>If the code is still shown, contact Customer Service.</p>

Code	Description	Possible Solutions
F15	DisChg Curr Over: The battery is discharged with over current.	<ol style="list-style-type: none"> 1. Wait five minutes for the inverter to restart automatically. 2. Check the backup loads. If the load exceeds the rated output power of the inverter, disconnect some load. <p>If the code is still shown, contact Customer Service.</p>
F16	Chg Curr Over: The battery is charging with over current.	<p>Check the battery wiring port for short circuits.</p> <p>Restart the inverter and the battery packs.</p> <p>If the code is still shown, contact Customer Service.</p>
F17	Current Sensor Fault: A failure occurred to the current sensor.	<p>Restart the inverter and wait until it runs correctly.</p> <p>If the code is still shown, contact Customer Service.</p>
F18	INV Abnormal: Abnormal output voltage or output frequency of the inverter.	<p>Contact Customer Service.</p>
F20	Always Over Load: The backup load always exceeds the rated output power of the system.	<p>Check the backup loads. If the load is lower than the rated output power of the inverter and the error is still shown, contact Customer Service.</p>
F21	SPI Fault Between DSP: A failure occurred to the communication between DSPs.	<p>Restart the inverter and wait until it runs correctly.</p> <p>Restart the inverter and wait until it runs correctly.</p>
F22	Parallel Communicate Fault: A failure occurred to the communication between the inverters in a parallel system.	<ol style="list-style-type: none"> 1. Check the parallel cable for connection. 2. Check the inverter address settings. In a parallel system, the address of the primary inverter must be set to 1, and the addresses of the other inverters must be set to 2, 3, or 4. <p>If the code is still shown, contact Customer Service.</p>
F23	Parallel Grid Abnormal: In a parallel system, some connections are incorrect.	<ol style="list-style-type: none"> 1. Check the wiring at the grid end and make sure the wiring is correct. 2. Restart the inverter and wait until it runs correctly. <p>If the code is still shown, contact Customer Service.</p>

Code	Description	Possible Solutions
F25	Parallel Power Imbalance: Power imbalance occurs to the parallel system.	<ol style="list-style-type: none"> 1. Turn off all the switches on the backup load end. 2. Restart the inverter and wait until it runs correctly.
F26	Parallel Inverter Grid Phase Sequence Abnormal	<ol style="list-style-type: none"> 1. Make sure that the phase sequence at the grid end of the inverter is consistent. 2. If the code is still shown, contact Customer Service.
F27	Rapid Shutdown	<p>Emergency button is pressed. Check that the photovoltaic plate is normal, and manual recovery emergency button after normal. If the code is still shown, contact Customer Service.</p>
F28	AFCI module Fault	<p>Restart the inverter and wait until it runs correctly. If the code is still shown, contact Customer Service.</p>
F29	AFCI continuous Fault	<p>Check the wiring between the inverter and the photovoltaic plate, and ensure that the connection points are tight. Restart the inverter and wait until it runs correctly If the code is still shown, contact Customer Service.</p>
F30	AFCI Fault	<p>Restart the inverter and wait until it runs correctly If the code is still shown, contact Customer Service.</p>
F32	DSP ARM SCI Fault: A failure occurs to the communication between DSP and ARM.	<p>Restart the inverter and wait until it runs correctly. If the code is still shown, contact Customer Service.</p>

7.3.2 Alarm Codes of the System

Code	Description	Possible Solutions
W00	Grid Volt Low	<p>Check the local voltage and frequency for their compliance with the inverter specifications:</p> <ul style="list-style-type: none"> • If the voltage and frequency are within the acceptable range, wait two minutes for the inverter to run correctly. If recovery is not possible or the fault repeats, contact Customer Service. • If the voltage and frequency are beyond the range or are unstable, contact the local power company.
W01	Grid Volt High	
W02	Grid Frequency Low	
W03	Grid Frequency High	
W04	Solar Loss: No PV solar panels are connected to the system, or the input voltage from the PV solar panels is too low.	<ol style="list-style-type: none"> 1. Check the PV connection. 2. Check the PV availability. <p>If the connections are correct and the alarm code is still shown, contact Customer Service.</p>
W05	Bat Loss: No battery packs are connected to the system, or the battery voltage is too low.	<ol style="list-style-type: none"> 1. Check the battery connection. 2. Check the battery wiring port for short circuits. <p>If the connections are correct and the alarm code is still shown, contact Customer Service.</p>
W06	Bat Under Volt: Under voltage has occurred in the battery.	<p>Check the battery packs for their availability. If the battery voltage is lower than the lowest battery terminal input voltage acceptable to the inverter, charge the battery until it reaches the acceptable battery input voltage of the inverter. If the code is still shown, contact Customer Service.</p>
W07	Bat Volt Low: The battery voltage is too low.	
W08	Bat Volt High: The battery voltage is higher than 57.5 V and the battery has shut down because of the high voltage.	<ol style="list-style-type: none"> 1. Check the battery for its compliance with its pre-settings. 2. If the battery complies with the pre-setting, restart it. <p>If the code is still shown, contact Customer Service.</p>
W09	Over Load: An overload has occurred because the connected load exceeds the rated power of the inverter.	<ol style="list-style-type: none"> 1. Wait five minute for the inverter to restart. 2. If the backup loads are higher than the rated output power of the inverter, disconnect some load.

Code	Description	Possible Solutions
W10	GFCI Over: High current leakage has occurred.	<ol style="list-style-type: none"> 1. Check the PV string for direct or indirect grounding. If such grounding is discovered, correct it. 2. Check the peripherals of the inverter for current leakage. If current leakage is discovered, address it. <p>If the code is still shown, contact Customer Service.</p>
W11	Grid L-N wiring error	<p>Check the LN connection of the power grid.</p> <p>If the grid L-N is connected correctly, restart it.</p> <p>If the code is still shown, contact Customer Service.</p>
W12	Fan Fault: The fan has malfunctioned.	<p>Restart the inverter and wait until it runs correctly.</p> <p>If the code is still shown, contact Customer Service.</p>
W13	BAT Power Down: The battery has shut down because the SOC is low.	<p>Check the SOC. Make sure that the SOC is not lower than the difference between 100% and the set DOD. If it is lower than the difference, charge the battery.</p>
W14 W15 W16 W17 W18 W21 W22	BMS alarms.	<p>For more information, see BMS ALARM Warnings.</p>
W19	BMS Volt Imbalance: A voltage imbalance has occurred to the battery of the BMS.	<p>Contact Customer Service.</p>
W20	BMS Communicate Fault: The communication between the BMS and the inverter has failed.	<p>Make sure that the COM cable between the inverter and the battery pack is in good condition and is connected correctly.</p>
W23 W24	BMS protection warning.	<p>For more information, see BMS PROTECTION Warnings.</p>
W25	BMS Updating: The BMS is updating.	<p>You can ignore this alarm. No action is required.</p>
W26	BMS Program Version Err: The version of the BMS program is incorrect.	<p>Contact Customer Service.</p>

Code	Description	Possible Solutions
W27	BMS Program Update Fail: The BMS program has failed to update.	Check the network and try to update the program again.
W29	Grid Volt Lock Fail: The inverter has failed to synchronize with the grid.	Restart the inverter and wait until it runs correctly. If the code is still shown, contact Customer Service.
W30	PV Off: The PV string has requested a shutdown.	Restart the inverter and wait until it runs correctly. If the code is still shown, contact Customer Service.
W31	System Reset: The system is reset.	Restart the inverter and wait until it runs correctly. If the code is still shown, contact Customer Service.
W32	PEN Volt High: The voltage of PE to N is high.	Restart the inverter and wait until it runs correctly. If the code is still shown, contact Customer Service.

7.3.3 BMS ALARM Warnings

When a battery pack is in the ALARM state, a LOW SOC warning and other ALARM warnings can occur.

For more information about the LOW SOC warning, see the [ALARM State](#), [FAULT State](#), and [PROTECTION State](#) subsection under [Indicator Lights and States](#).

When the OPERATION indicator light blinks THREE times and the FAULT indicator light is OFF, you can know the other ALARM warnings through the states of the SOC indicator lights and the alarm codes shown on the LCD screen of the inverter. [Table 7-1](#) lists these ALARM warnings. In this table, “MODULE” means a battery pack and “CELL” means a battery cell.



You can also check the alarm codes through **INQUIRE -> BMS INFO** in the integrated EMS. For more information, see [Viewing INQUIRE](#).

“N/A” (Not Applicable) in the “Code” column of [Table 7-1](#) means no code is assigned to the alarm.

Table 7-1 ALARM State: Indicator Lights, Codes, and Possible Solutions

Code	ALARM Warning	SOC (From Bottom to Top)				Description	Possible Solutions
W16	MODULE OVER VOLTAGE	ON	ON	ON	ON	The battery is nearing full charge.	You can ignore this alarm. No action is required.
W21	MODULE UNDER VOLTAGE	OFF	ON	ON	ON	The battery nearing full discharge.	You can ignore this alarm. No action is required.
W16	CELL OVER VOLTAGE	ON	OFF	ON	ON	The battery is nearing full charge.	You can ignore this alarm. No action is required.
W21	CELL UNDER VOLTAGE	OFF	OFF	ON	ON	The battery is nearing full discharge.	You can ignore this alarm. No action is required.
W17	CELL OVER TEMPERATURE	ON	OFF	OFF	ON	The cell temperature is too high.	You can ignore this alarm. No action is required.
Charge: W18 Discharge: W22	CELL UNDER TEMPERATURE	OFF	OFF	OFF	ON	The cell temperature is too low.	You can ignore this alarm. No action is required.
W15	CHARGING OVER CURRENT	ON	ON	ON	OFF	The charging current is too high.	Lower the charging current.
W14	DISCHARGE OVER CURRENT	OFF	ON	ON	OFF	The discharging current is too high.	Lower the discharging current.
N/A	LOW SOC ALARM	ON	ON	OFF	OFF	When the battery pack runs in the IDLE or DISCHARGE mode, a LOW SOC alarm can occur when SOC is too low.	Recharge the battery. For more information, see Recharging a Battery .

7.3.4 BMS FAULT Warnings

When the **OPERATION** indicator light blinks THREE times and the **FAULT** indicator light is OFF, the battery pack is in the FAULT state. You can know the FAULT warnings through the SOC indicator lights and the alarm codes shown on the LCD screen of the inverter.

When a FAULT warning occurs, you must contact Customer Service.

[Table 7-2](#) lists all FAULT warnings. In this table, “MODULE” means a battery pack and “CELL” means a battery cell.



You can also know the alarm codes through **INQUIRE -> BMS INFO** in the integrated EMS. For more information, see [Viewing INQUIRE](#).

“N/A” (Not Applicable) in the “Code” column of [Table 7-2](#) means no code is assigned to the alarm.

Table 7-2 FAULT State: Indicator Lights, Codes, and Possible Solutions

Code	FAULT Warning	SOC (From Bottom to Top)				Description	Possible Solutions
N/A	CHARGE MOS FAULT	ON	ON	OFF	ON	When the charging MOSFET is OFF, the current on the circuit is positive.	Disconnect the release to disable the battery pack and contact Customer Service to check the charging MOSFET on the BMS circuit board for short circuits.
N/A	DISCHARGE MOS FAULT	OFF	ON	OFF	ON	When the discharging MOSFET is OFF, the current on the circuit is negative.	Disconnect the release to disable the battery pack and contact Customer Service to check the discharging MOSFET on the BMS circuit board for short circuits.
N/A	CELL SAMPLING FAULT	ON	OFF	ON	OFF	BMS fault.	Contact Customer Service to check the cell sampling wires and the wiring of the BMS circuit board. Make sure that the BMS circuit board is powered correctly.

Code	FAULT Warning	SOC (From Bottom to Top)				Description	Possible Solutions
N/A	HEATING FAULT	OFF	OFF	ON	OFF	BMS fault.	Contact Customer Service to check the heating film circuit. Make sure that the three-terminal fuse is not blown and the circuit is running correctly.
N/A	TEMPERATURE SENSOR MALFUNCTION	OFF	ON	OFF	OFF	BMS fault.	Contact Customer Service to check the connection of the temperature sensor and wiring of the BMS circuit board. Make sure that the temperature sensor is running correctly.
N/A	BATTERY CELL MALFUNCTION	ON	OFF	OFF	OFF	The voltage difference between cells exceeds 1 V.	Contact Customer Service to check the cell sampling wires and the wiring of the BMS circuit board. Make sure that the BMS circuit board is powered correctly.
N/A	COMMUNICATION FAILURE	OFF	OFF	OFF	OFF	Internal communication of the battery pack has failed.	Contact Customer Service to check the circuit board.

7.3.5 BMS PROTECTION Warnings

When the **OPERATION** indicator light blinks THREE times and the **FAULT** indicator light is ON, the battery pack is in the PROTECTION state.

Under a condition that causes the PROTECTION state, the battery management system (BMS) automatically protects the battery pack and makes the battery pack enter the PROTECTION state. When the condition is no longer present, the PROTECTION warning is cleared automatically and the battery pack automatically exits the PROTECTION state. If a PROTECTION warning cannot be cleared automatically, contact Customer Service.

You can know the PROTECTION warnings through the SOC indicator lights and the alarm codes shown on the LCD screen of the inverter. [Table 7-3](#) lists all

PROTECTION warnings. In this table, “MODULE” means the battery pack and “CELL” means the battery cell.



You can also know the alarm codes through **INQUIRE -> BMS INFO** in the integrated EMS. For more information, see [Viewing INQUIRE](#).

“N/A” (Not Applicable) in the “Code” column of [Table 7-3](#) means no code is assigned to the protection warning.

Table 7-3 PROTECTION State: Indicator Lights, Codes, and Possible Solutions

Code	PROTECTION Warning	SOC (From Bottom to Top)				Description	Possible Solutions
N/A	SHORT CIRCUIT PROTECTION	ON	ON	ON	ON	The discharging current is too high.	When this warning occurs, the BMS will disconnect the discharging circuit for 30 seconds. During the disconnection, you must remove the external loads of the battery pack. 30 seconds later, the SHORT CIRCUIT PROTECTION warning will be automatically cleared.
N/A	CHARGE PROTECTION MODULE OVER VOLTAGE	OFF	ON	ON	ON	The battery is fully charged.	The BMS will disconnect the charging circuit automatically. DO NOT continue charging the battery pack.
N/A	PROTECTION MODULE OVER CURRENT	ON	OFF	ON	ON	The current is higher than the set threshold.	The BMS will disconnect the circuit automatically. One minute later, the connection will be restored. You should limit the current.

Code	PROTECTION Warning	SOC (From Bottom to Top)				Description	Possible Solutions
W23	PROTECTION MODULE OVER VOLTAGE	OFF	OFF	ON	ON	The total voltage of the battery has been charged to the upper limit.	The BMS will disconnect the charging circuit automatically. DO NOT continue charging the battery.
N/A	PROTECTION MODULE UNDER VOLTAGE	ON	ON	OFF	ON	The total voltage of the battery has been discharged to the lower limit.	The BMS will disconnect the discharging circuit automatically. You must recharge the battery. For more information, see Recharging a Battery .
N/A	PROTECTION REVERSE POLARITY	OFF	ON	OFF	ON	The positive and negative polarities are reversed.	Check the connection of the power supply of the battery pack for reverse connection.
N/A	CELL OVER VOLTAGE	ON	OFF	OFF	ON	The battery cell has been charged to the upper limit.	The BMS will disconnect the charging circuit automatically. DO NOT continue charging the battery pack.
N/A	CELL UNDER VOLTAGE	OFF	OFF	OFF	ON	The battery cell has been discharged to the lower limit.	The BMS will disconnect the discharging circuit automatically. You must recharge the battery. For more information, see Recharging a Battery .

Code	PROTECTION Warning	SOC (From Bottom to Top)				Description	Possible Solutions
W24	CELL OVER TEMPERATURE CHARGE/ DISCHARGE	ON	ON	ON	OFF	The temperature of the battery cell has reached the upper limit.	Check the ambient temperature around the battery pack. Make sure that the temperature is not too high. Make sure that the battery is not fully charged and discharged for a long period of time.
N/A	CELL UNDER TEMPERATURE CHARGE/ DISCHARGE	OFF	ON	ON	OFF	The temperature of the battery cell has reached the lower limit.	Check the ambient temperature around the battery pack. Make sure that the temperature is not too low.
N/A	AMBIENT OVER TEMPERATURE	ON	OFF	ON	OFF	The ambient temperature has reached the upper limit.	Check the ambient temperature around the battery pack. Make sure that the temperature is not too high.
N/A	AMBIENT UNDER TEMPERATURE	OFF	OFF	ON	OFF	The ambient temperature has reached the lower limit.	Check the ambient temperature around the battery pack. Make sure that the temperature is not too low.

Code	PROTECTION Warning	SOC (From Bottom to Top)				Description	Possible Solutions
N/A	MOSFET OVER TEMPERATURE	ON	ON	OFF	OFF	The temperature of the MOSFET has reached the upper limit.	Check the ambient temperature around the battery pack. Make sure that the current is not too high. Make sure that the battery is not fully charged and discharged for a long period of time.
N/A	LOCKED	OFF	OFF	OFF	OFF	The battery pack is locked because the voltage or the temperature exceeds the upper limits or falls below the lower limit. When the battery pack is locked, charging or discharging is not permitted.	Make sure there is no over voltage, under voltage, over temperature, or under temperature protection warning, and then press the button and hold it for 20 seconds to unlock the battery pack.

8 Storing and Recharging Batteries

8.1 Storage Environment Requirements

It is recommended that you begin using the battery soon after delivery rather than store the battery pack for a long time. The maximum storage life of a battery pack is three years.

The intended storage environment of the battery pack must meet these requirements:

- Ambient temperature: -10°C to 45°C.
- Recommended storage temperature: 20°C to 30°C.
- Relative humidity: 0–95% (No condensation).
- Dry, ventilated, and clean area.
- No contact with corrosive organic solvents, gases, and other substances.
- No direct sunlight.
- More than two meters from any heat source.

WARNING

When storing a battery in its packaging, make sure that the packaging box is intact and that the battery is appropriately placed and stacked, and the above mentioned requirements are met.

8.2 Interval for Recharging Batteries

While in storage, batteries must be recharged at specified intervals.

Table 8-1 Recharge Batteries at Specified Intervals During Storage

Actual Storage Temperature	Interval
$-10^{\circ}\text{C} \leq T \leq 30^{\circ}\text{C}$	12 months
$30^{\circ}\text{C} < T \leq 45^{\circ}\text{C}$	8 months

Battery packs must be recharged a maximum of three times within a 3-year period. For example, whether the battery is recharged every 8 months or every 12 months, it can only be recharged a maximum of three times within three years. If the battery has not been recharged within three years, or if it has been recharged more than three times within three years, it is recommended that the battery pack be discarded.

Lithium-ion batteries lose capacity during storage. After 12 months of storage at the intended storage temperature, the capacity generally falls irreversibly by 3–10%. Batteries with less than 100% capacity after storage cannot pass the discharge testing and acceptance testing.

8.3 Recharging a Battery

If a battery has not been charged for two weeks or more after a deep discharge, or the SOC of a battery is less than 50% after a long period of storage, the battery must be charged to 50%.

WARNING

Before charging the battery, check it for deformation, case damage, or leakage, and if you find any of these things, do not charge the battery.



If the SOC of a battery pack is not less than 50% after more than 12 months of storage, it is not necessary to recharge the battery.

NOTES

Prepare a cross screwdriver and insulated rubber gloves.

CAUTION

When you connect the power wires, wear insulated rubber gloves.

PROCEDURE

- Step 1.** If the battery pack has been stored for a long time, unpack the battery pack and connect it to the system.
- Step 2.** On the integrated EMS, set **DISC DEPTH** to **95%**. For more information, see the [DISC DEPTH](#) subsection under [BAT SETTING](#).
- Step 3.** On the integrated EMS, set **WORK MODE** to **PEAK SHIFT** and set the inverter to **DISCHG**. For more information, see the [WORK MODE](#) subsection under [SYS SETTING](#).

On the battery pack, press the button. Check the indicator lights. If only the bottom one or two SOC indicator lights are ON and the **FAULT** indicator light is OFF, then the battery pack is in good working order.



If the battery is in good working order, contact Customer Service.

- Step 4.** Use the COM cable to connect the BAT port inside the cable box and the INV port on the battery pack, and then use the BAT cables to connect the BAT+ and BAT- ports inside the cable box and the battery pack.
- Step 5.** On the side of the battery pack, set the DC Switch or Battery Switch to ON, and inside the cable box, set the Battery Switch to ON.



When only one battery pack is connected to a three-phase inverter, the **PROTECTION MODULE OVER CURRENT** warning can occur after flipping the Battery Switch inside the cable box. To solve it, follow these steps:

- 1 Set the Battery Switch inside the cable box and the DC Switch or Battery Switch on the side of the battery pack to the OFF position.
- 2 On the battery pack, press the button and hold it for six seconds to restart the battery pack.

- Step 6.** On the battery pack, press the button and hold it for three seconds to turn on the battery pack.
- Step 7.** On the LCD screen, view the **BATTERY** and **BMS PARAM** information. For more information, see [Viewing the Current System Information](#). The rated charge and discharge current of the battery are 50 A and **80 A**.
- Step 8.** Wait for the inverter to discharge the battery. On the **BATTERY** page, the discharge current is in the range of 70 A–80 A.
- Step 9.** On the **BMS PARAM** page, check the SOC. When the battery is discharged to less than 4%, the inverter reports **W07** and **W13**, as shown on the **ERROR NO.** page.
- Step 10.** On the **WORK MODE** page of the integrated EMS, enable **SELF CONSUME**, set **CHARGE TIME** to **00:00–23:59**, and set MAX SOC to **50%**. For more information, see the [WORK MODE](#) subsection under [SYS SETTING](#).
- Step 11.** Wait for the inverter to charge the battery. On the **BATTERY** page, the charge current is in the range of 40 A–50 A.
- Step 12.** When the **MAX SOC (50%)** is reached, as shown on the **BMS PARAM** page, power off the battery pack, set the Battery Switch or Battery Switch inside the cable box to OFF, set the DC Switch on the side of the battery pack to OFF, and disconnect the COM cable and the BAT cables between BAT+ and BAT-.
- Step 13.** Close the side cover of the battery pack.
- Step 14.** If the battery pack was stored, move the battery pack into the package box.

Step 15. If more battery packs must be recharged, follow steps 1 through 15.

Step 16. After all the battery packs are recharged, reset the inverter to the default factory settings. For more information, see [Restoring Factory Settings \(FCTRY RESET\)](#).

9 Limited Warranty

If the equipment fails during the warranty period, COMPAny and its authorized partners will provide free service or replace the unit or part with a new one.

9.1 When the Warranty Period Starts and Ends

Starting from the date on which you purchase the equipment, you are entitled to these warranty services:

- A 5-year product warranty service for the hybrid inverter and the battery packs.
- A 10-year performance warranty service for the battery packs.

9.2 What This Warranty Covers

During the warranty service, the professional personnel certified by COMPAny or its authorized partners will determine the problem based on the current status of the equipment, confirm the time required for repair or replacement, and complete the repair or replacement within the agreed time.

If a unit or part is replaced, the replaced unit or parts will be recycled and disposed of by COMPAny or its authorized partners.

The replacement unit or parts provided by COMPAny are determined by the inventory and may not be brand new, but are bound to be in good working condition and at least functionally equivalent to a brand new unit or part. The replacement unit or part will be warranted for the remainder of the original warranty period of the equipment.

9.3 How to Obtain Warranty Service

If the equipment does not function as warranted during the warranty period, you can contact COMPAny or its authorized partners to obtain warranty service.

9.4 Customer Responsibility for Warranty Service

To obtain warranty service, you must take these steps:

- Step 1.** Provide the purchase invoice to prove that the whole unit or parts are still under warranty.
- Step 2.** Make sure that the nameplate on the equipment is intact and legible.
- Step 3.** Make sure that the installation, modification, replacement, or removal of the whole unit or part of the equipment has been done by professional personnel certified by COMPAny or its authorized partners.
- Step 4.** Make sure that the equipment has been operated in the intended environment described in this manual or other documents provided by COMPAny.

Step 5. Make sure that no non-standard parts or parts not supplied by COMPAny are used in the equipment.

Failure to comply with any of the above information, COMPAny or its authorized partners have the right to refuse to provide warranty service.

9.5 Limitation of Liability

COMPAny has the right to refuse to honor the quality warranty for any of the following reasons:

- Damage during transportation, including paint scratches caused by friction inside the package during transportation, and damage sustained while being transported by you or a third party commissioned by you.
- Operation of the equipment in an environment other than the intended environment described in this manual or other documents provided by COMPAny.
- Failure or damage caused by installation, repair, modification, or disassembly carried out by anyone other than professional personnel certified by COMPAny or its authorized partners.
- Failure or damage caused by the use of non-standard components or other components not provided by COMPAny.

COMPAny may charge a fee for repair service if you request repair of the equipment in any of the following circumstances:

- Installation and use beyond the scope of the relevant standards.
- Damage caused by unexpected natural factors.

10 Emergency Procedure

An emergency is a situation involving a major incident or the possibility of a major incident that cannot be handled according to normal procedures and requires immediate action to limit or address the consequences.

This section describes emergencies that may be encountered when you are using the E8KD/E10KD/E12KD/E15KD energy storage system and how to handle such emergencies.

10.1 General Handling

If an emergency occurs, remember the following:

- The grid main switch that supplies power directly to the BESS must be turned off.
- All load switches in the BESS must be turned off.
- The battery switch must be turned off.
- If you want to open the inverter or the battery pack after the power is turned off, to prevent possible fatal personal injury, use a properly calibrated voltage meter to measure the voltage at the input terminals, wait approximately 15 minutes until the DC link capacitors inside the battery pack is completely discharged, and then open the top cover to repair.

WARNING

Before operating the equipment, make sure that the BESS is not supplied with grid power.

10.2 Potential Emergencies

10.2.1 Battery Leakage

If the battery pack leaks electrolyte, avoid contact with the leaking liquid or gas. If you contact with the leaking substance, take the measures listed in [Table 10-1](#) immediately.

Table 10-1 Measures to Solve Battery Leakage Emergency

Exposure	Measures
Inhalation	Evacuate contaminated area, and then seek medical attention.
Eye Contact	Flush eyes with running water for five minutes, and then seek medical attention.

Skin Contact	Wash affected area thoroughly with soap and water, and then seek medical attention.
Ingestion	Induce vomiting, and then seek medical attention.

10.2.2 Fire or Explosion

If a fire occurs in the area where the battery pack is installed, take the following measures.

 **WARNING**

Batteries can explode when heated over 150°C. Toxic gases can leak when a battery pack burns. DO NOT approach. However, because the batteries contain only a small amount of oxygen and all batteries are equipped with explosion-proof valves, battery explosions are unlikely to occur.

Table 10-2 Handling with Fire

Handling with Fire	Description
Fire Extinguishing Agent	A respirator is not usually required. If the fire is caused by a battery, use a specialized fire extinguisher such as Noves 1230, FM-200, or a dioxin extinguisher. If the fire is not caused by a battery, use a regular ABC extinguisher.
Extinguishing Instructions	If a fire occurs while charging a battery, turn off the battery pack circuit breaker and turn off the charging power if it is safe to do so. If the battery pack is not on fire, the fire should be extinguished before the battery pack catches fire. If the battery pack is on fire, do not attempt to extinguish the fire. Instead, evacuate personnel immediately.

Methods of Handling Accidents	If the battery is in a dry environment, put the damaged battery in an isolated area and call the local fire department or service engineer. If the battery is in a wet environment, DO NOT touch anything if any part of the battery, such as the inverter or cables, is submerged. DO NOT use the submerged battery. Contact a service engineer.
-------------------------------	--

10.3 Emergency Handling Plan

If an emergency occurs, follow this emergency handling plan:

- Step 1.** Turn off the AC circuit breakers.
- Step 2.** Check the control power supply. If there is no problem, supply power to the inverter again to find the cause.
- Step 3.** Record the details related to the fault so that COMPAny can analyze and rectify the fault. DO NOT operate the equipment before the fault is rectified. Please contact COMPAny as soon as possible.

CAUTION

When the FAULT indicator light on the battery pack is ON, please do a check and contact our Customer Service.

11 Disposal

When the system reaches the end of its service life, follow these steps to dispose of the equipment:

Step 1. Uninstall the system:

- 1.1 Disconnect all power sources.
- 1.2 Disassemble all parts of the system from top to bottom.

Step 2. Dispose of all the parts. **DO NOT** dispose of the inverters, the battery packs, and the stick loggers as regular household waste.

	<p>This symbol means that the labeled equipment must not be disposed of as regular household waste. It must be disposed of at an electrical and electronic equipment-recycling center.</p>
---	--

NOTICE

If you need to replace a battery pack, you should request a new dangerous goods package, pack the battery pack, and then have the supplier pick it up.

COMPANY does not recycle batteries. Please contact your local recycling organization for disposal. If there is no local recycling organization, you should contact the nearest recycling organization in your country.

12 Specifications

12.1 Hybrid Inverter

Dimension (W × H × D, mm)	540 × 1050 × 240
Net Weight (kg)	73
Operating Temperature	-20°C to +55°C, derated over 50°C
Operating Relative Humidity	0–95% (No condensation)
Operating Altitude	≤ 2000 m
Protective Class	Class II
Overvoltage Category	II (DC side), IV (AC side)
Topology	High Frequency Isolation
Cooling	Fan cooling
Display	LCD/APP
Communication Interface	RS485, CAN2.0, Wi-Fi
Ingress Protection	IP66
Max. Conversion Efficiency (From Battery)	95.0%
Max. Conversion Efficiency (From PV)	97.0%
CEC Efficiency(From PV, Grid 208Va.c.)	96.0%
CEC Efficiency(From Battery, Grid 208Va.c.)	94.0%
CEC Efficiency(From PV, Grid 240Va.c.)	97.0%
CEC Efficiency(From Battery, Grid 240Va.c.)	95.0%
MPPT Efficiency	99.5%
Protection Function	<ul style="list-style-type: none"> • Short Circuit Protection • AC Leakage Fault Protection • Grounding Fault Protection • Anti-islanding Protection • Overload Protection • Surge Protection • DC arc fault protection for photovoltaic applications
Grid Regulation	<ul style="list-style-type: none"> • IEEE Std 1547-2018 • IEEE Std 1547.1-2020 • UL1741SB

Safety Regulation	<ul style="list-style-type: none"> • UL1741 • CSA C22.2 No.107.1 • CSA C22.2 No.292 • CSA C22.2 No.330 • UL1699B
EMC	<ul style="list-style-type: none"> • FCC Part15B:2021 • ICES-003, Issue 7, • Class B

12.2 Battery Terminal Input/Output

	E8KD	E10KD	E12KD	E15KD
Battery Type	Lithium batteries			
Voltage Range	44.0–57.0 VDC			
Rated Voltage	51.2 VDC			
Maximum Charge/ Discharge Current	160 ADC/200 ADC	160 ADC/200 ADC	200 ADC/240 ADC	200 ADC/240 ADC
Maximum Charge/ Discharge Power	8,000 W /8,000 W	8,000 W /10,000 W	10,000 W /12,000 W	10,000 W /12,000 W

12.3 PV Input

	E8KD	E10KD	E12KD	E15KD
Vmax. PV	500 VDC			
Rated Voltage	400 VDC			
PV Start Voltage	120 VDC (Adjustable Range 120–500 VDC)			
MPPT Voltage Range	120–480 VDC			
MPPT Range (Full Load)	200–425 VDC	240–425 VDC	200–425 VDC	240–425 VDC
No. of MPPT /Strings per MPPT	2/2		3/2	
Max. Continuous PV Input Current (each MPPT)	30 ADC			
Max. Continuous PV Input Current (each Strings)	15 ADC			

Isc PV	40 ADC × 2		40 ADC × 3	
Max. Input Power per MPPT	9000W			
Max. Continuous PV Input Power	16,000 W	18,000 W	22,000 W	25,000W

12.4 Grid Terminal Input/Output

	E8KD	E10KD	E12KD	E15KD
Rated Voltage	240/208Va.c.			
Rated Frequency	50 Hz /60 Hz			
Maximum Continuous Input Current	150 Aa.c.			
Maximum Input Current	200 Aa.c.			
Maximum Continuous Input Power	36,000W			
Maximum Input Power	48,000W			
Rated Output Current	33.3 Aa.c.	42.0 Aa.c.	50.0 Aa.c.	62.5 Aa.c.
Maximum Continuous Output Current	33.3 Aa.c.	42.0 Aa.c.	50.0 Aa.c.	62.5 Aa.c.
Power factor (Cos phi), Adjustable	0.8 leading–0.8 lagging			
Rated Output Power	8,000 W	10,000 W	12,000 W	15,000 W
Max Output Power(From Battery)	8,000 W	10,000 W	11,400 W	11,400 W
Maximum Continuous Output Apparent Power	8,000 VA	10,000 VA	12,000 VA	15,000 VA
Grid Port Overcurrent Protection	200 Aa.c.			

12.5 Backup Load Terminal Output(Off Grid)

	E8KD	E10KD	E12KD	E15KD
Rated Voltage(L-L)	240/208Va.c.			
Rated frequency	50 Hz/60 Hz			
Rated Output Current(L-L)	33.3 Aa.c.	42.0 Aa.c.	50.0 Aa.c.	50.0 Aa.c.

Rated Output Current(L-N)	33.3 Aa.c.	42.0 Aa.c.	50.0 Aa.c.	50.0 Aa.c.
Maximum Continuous Output Current(L-L)	33.3 Aa.c.	42.0 Aa.c.	50.0 Aa.c.	50.0 Aa.c.
Maximum Continuous Output Current(L-N)	50.0 Aa.c.	50.0 Aa.c.	62.5 Aa.c.	62.5 Aa.c.
Rated Continuous Output Power (L-L)	8,000 W	10,000 W	12,000 W	12,000 W
Max Output Power(L-L) (From Battery)	8,000 W	10,000 W	11,400 W	11,400 W
Maximum Output Apparent Power(L-L)	8,000 VA	10,000 VA	12,000 VA	12,000 VA
Maximum Output Reactive power(L-L)	4000var	5000var	6000var	6000var
Maximum Output Apparent Power(L-N)	6,000 VA	6,000 VA	7500 VA	7500 VA
Backup Load Overcurrent Protection	200 Aa.c.			

12.6 Backup Load Terminal Output (Grid-Tied)

	E8KD	E10KD	E12KD	E15KD
Rated Output Current	150 Aa.c.			
Maximum Output Current	200 Aa.c.			
Rated Continuous Output Power	36,000 W			
Maximum Output Power	48,000 W			
Backup Load Overcurrent Protection	200 Aa.c.			

12.7 Battery Pack (BP48100PF)

Dimension (W × H × D, mm)	540 × 490(excluding handle) × 240
Net Weight (kg)	56.5
Battery Type	LFP (LiFePO4)
IP Protection	IP66
Safety (Battery pack)	<ul style="list-style-type: none"> • UL 1973 • FCC Part 15 Class B • UL9540A

Safety (Battery Cell)	<ul style="list-style-type: none">• UL 1973• UL9540A
Operating Temperature Range	-10°C to +50°C
Storage Temperature Range	-10°C to +45°C
Operating Relative Humidity	0–90% (No condensation)
Battery Capacity	5 kWh
Available capacity	4.5 kWh
Rated Voltage	51.2 V
Depth of Discharge (DOD)	90%
Operating Voltage Range	44.8–57.6 VDC
Maximum Charging Current	50 A (0.5C)
Maximum Discharging Current	80 A (0.8C)
BMS Modules Connection	A maximum of 8 batteries in parallel

Communication	CAN (to the inverter)/RS485 (to the battery pack)
Installation method	Floor installation

13 Abbreviations

A

AC	Alternating Current
AFCI	Arc-Fault Circuit-Interrupter
App	Application
AWG	American Wire Gauge

B

BESS	Battery Energy Storage System
BMS	Battery Management System

C

CT	Current Transformer
----	---------------------

D

DC	Direct Current
DOD	Depth of Discharge
DRED	Demand Response Enabling Device
DRM	Demand Response Mode
DSP	Digital Signal Processor

E

EMI	Electromagnetic Interference
EMS	Energy Management System
EPS	Emergency Power Supply

G

GFCI	Ground Fault Circuit Interrupter
------	----------------------------------

I

ISO	Insulation
-----	------------

M

MPPT	Maximum Power Point Tracker
------	-----------------------------

P

PV	Photovoltaic
PE	Chassis grounding

R

RCD	Residual Current Device
RESP	Response
RRCR	Radio Ripple Control Receiver
RSD	Rapid Shutdown Device

S

SCI	Serial Communication Interface
SOC	State of Charge

14 Appendix: Definition of DVC

Decisive voltage Classification (DVC)	Limits of working voltage V		
	a.c. voltage r.m.s. U_{ACL}	a.c. voltage peak U_{ACPL}	d.c. voltage mean U_{DCL}
A*	25 (16)	35.4 (22.6)	60 (35)
B	50 (33)	71 (46.7)	120 (70)
C	> 50 (> 33)	> 71 (> 46.7)	> 120 (> 70)

The table values in parentheses are to be used for PCE or portions of PCEs rated for installation in wet locations as addressed in 6.1 for environmental categories and minimum environmental conditions.

*DVC-A circuits are allowed under fault conditions to have voltages up to the DVC- B limits, for maximum 0.2 s.

KSTAR

Shenzhen Company Company Limited

Add:Kstar Industrial Park, Guangming Hi-Tech Park,
shenzhen ,P.R.CHINA

Tel:0755-21389008

Fax:0755-21389008

Web:www.kstar.com